

High Pressure Dryer HDK-MT

15/100—70/100

15/350—70/350

Dokument-ID: DMN-HDK-MT15-70/R06



Operating Instructions

Revision 06—07-2016 /EN

CE 0525

Declaration of Conformity

Parker Hannifin Manufacturing Germany GmbH & Co. KG
Gas Separation and Filtration Division EMEA

Im Teelbruch 118

D – 45219 Essen Kettwig

hereby declares with sole responsibility, that the products

High-pressure Dryer

Series HDK-MT 15/100 to 70/350

Assembly type: assembly acc. to Art. 4 No. 2b,

which this declaration refers to, conform to Directive **2014/68/EU** and were subjected to a conformity assessment according to Annex III Modules B + D (for assembly assessment).

For the assembly, the EC type approval certificate DTM0506108 by Lloyd's Register Quality Assurance GmbH, Hamburg, is available.

The quality assurance system is monitored by the service provider stated below
Lloyd's Register Quality Assurance GmbH (identification number 0525)
Am Sandtorkai 41, D - 20457 Hamburg.

The assembly consists of pressure appliances according to the classification list (attached to the technical documentation provided by the manufacturer).

Pressure vessel					
Dryer	Quantity	Allowable pressure (PS)	Volume [l]	Category (PED)	Module
HDK-MT 15 / 100	2	100	6,1	II	H (D1, E1)
HDK-MT 20 / 100	2	100	8,6	II	H (D1, E1)
HDK-MT 25 / 100	2	100	11,04	III	H
HDK-MT 30 / 100	2	100	13,5	III	H
HDK-MT 40 / 100	2	100	19,33	III	H
HDK-MT 50 / 100	2	100	22,9	III	H
HDK-MT 70 / 100	2	100	28,2	III	H
HDK-MT 15 / 350	2	350	3,5	III	H
HDK-MT 20 / 350	2	350	4,96	III	H
HDK-MT 25 / 350	2	350	6,4	III	H
HDK-MT 30 / 350	2	350	7,8	III	H
HDK-MT 40 / 350	2	350	12,4	IV	H 1
HDK-MT 50 / 350	2	350	14,7	IV	H 1
HDK-MT 70 / 350	2	350	18,1	IV	H 1

Piping (100 / 350 bar)				
Dryer	Allowable pressure (PS)	Dimensions (DN)	Category (PED)	Module
HDK-MT 15 / ...	400	DN15	Art.4.3	Art.4.3
HDK-MT 20 / ...	400	DN15	Art.4.3	Art.4.3
HDK-MT 25 / ...	400	DN15	Art.4.3	Art.4.3
HDK-MT 30 / ...	400	DN15	Art.4.3	Art.4.3
HDK-MT 40 / ...	400	DN20	Art.4.3	Art.4.3
HDK-MT 50 / ...	400	DN20	Art.4.3	Art.4.3
HDK-MT 70 / ...	400	DN20	Art.4.3	Art.4.3

Filter						
Dryer	Filter	Quantity	Allowable pressure (PS)	Volume [l]	Category (PED)	Module
HDK-MT 15 / 100	GH7	2	100	0,52	I	B+D
HDK-MT 20 / 100	GH7	2	100	0,52	I	B+D
HDK-MT 25 / 100	GH7	2	100	0,52	I	B+D
HDK-MT 30 / 100	GH7	2	100	0,52	I	B+D
HDK-MT 40 / 100	GH9	2	100	1,33	I	B+D
HDK-MT 50 / 100	GH9	2	100	1,33	I	B+D
HDK-MT 70 / 100	GH9	2	100	1,33	I	B+D
HDK-MT 15 / 350	GH7	2	350	0,52	III	H
HDK-MT 20 / 350	GH7	2	350	0,52	III	H
HDK-MT 25 / 350	GH7	2	350	0,52	III	H
HDK-MT 30 / 350	GH7	2	350	0,52	III	H
HDK-MT 40 / 350	GH9	2	350	1,34	III	H
HDK-MT 50 / 350	GH9	2	350	1,34	III	H
HDK-MT 70 / 350	GH9	2	350	1,34	III	H

The following standards / technical specifications were used:

Harmonized standards: DIN EN ISO 12100:2011-03, DIN EN 61000-6-3, DIN EN 61000-6-4

The following other EC directives were used:

- 2014/30/EU
- 2014/35/EU

Essen,

19.07.2016

Datum / Date

i. V. Dr. Jürgen Timmler
 Leiter Technik und Entwicklung /
 Manager Engineering and Development

Machine passport

It is the responsibility of the owner,

- to enter for the first time any appliance data not stated above,
- to keep these appliance data up to date.

Type designation	HDK-MT__
Order no.	
Project no.	
Build no.	
Vessel no.	
Vessel no.	
Year of manufacture	

The above-stated appliance data provide for a clear identification of the dryer and its components, and significantly facilitate any service measures.

Note:

Further important data on the dryer such as the details on the permissible operating pressure and the electrical connection are found on the type plate (for position of the type plate see page 12).

Table of contents

General Information.....	7
Manufacturer's details.....	7
Details on the dryer.....	7
About these operating instructions.....	8
Intended use of the dryer.....	9
For your own safety.....	9
General safety notes.....	10
Signs and hazard areas on the dryer.....	12
Technical Description	14
Layout.....	14
Function.....	15
Standard equipment	16
Available options.....	16
Transportation, installation and storage.....	18
What to do in the case of transport damage occurring?	18
Transporting the dryer to its installation site.....	19
Installing and anchoring the dryer	19
Storing the dryer	21
Installation.....	22
Recommended installation.....	22
Requirements for installation.....	23
Connect piping.....	23
Installing the electrical connection.....	24
Operating and control elements	26
Commissioning.....	29
Requirements for initial start-up	30
Dryer settings.....	30
Emergency shutdown	31
Start up dryer.....	31
Recommended operating modes in the individual phases	33
Monitoring dryer operation.....	34
With dewpoint-sensing control	34
Shutting down and restarting the dryer	35
Shutting down and depressurising the dryer	35
If work is to be carried out on the electrical system	36
Re-start.....	36

Maintenance and repair of the dryer.....	37
Notes on maintenance.....	37
Regular maintenance intervals	38
Instructions for use of the dongle.....	39
HDK-MT special tool kit.....	40
Perform a weekly visual inspection.....	41
Maintenance work to be completed every 12 months	42
Maintenance work to be completed every 24 months	47
Other maintenance work	55
Identifying and eliminating faults	60
Overview of faults.....	60
Index	63
Annex with technical documentation	65
Technical data.....	66
Replacement and wear parts list	68
Logic control diagram	71
Flow diagram.....	73
Dimensional drawing	74

General Information

Manufacturer's details

Name and address



*Parker Hannifin Manufacturing Germany GmbH & Co. KG
Gas Separation and Filtration Division EMEA*

Im Teelbruch 118
D-45219 Essen

Phone ++49 (0) 2054 934-0
Fax ++49 (0) 2054 934-164

Internet <http://www.parker.com>

Details on the dryer

Standard scope of delivery

Dryer, comprising

- 2 towers with a top and bottom valve block.
filled with desiccant
- 1 prefilter
- 1 after-filter
- 1 muffler
- 1 dewpoint sensor
- 1 control system

Associated documents

- Circuit diagrams (see separate document)

Notes on accompanying documentation

Accompanying documents such as operating instructions for options or related components must always be taken into account. These contain additional information such as in respect of maintenance and are therefore essential for safe operation of the system.

About these operating instructions

These operating instructions contain basic information on the safe use of the dryer.

Characters and symbols used

- ▶ Work steps that you have to carry out in the sequence stated are marked by black triangles.
- Lists are marked by a small box.

Note:

These notes provide you with hints and information on the safe and efficient handling of machines and devices.



Attention!

These safety notes warn against damage to property and help you to avoid such damage.



Danger!

These danger notes with a grey background warn against personal injury and/or danger to life and limb; danger notes help you to avoid serious or life-threatening situations for yourself and/or third parties.

Target group of these operating instructions

These operating instructions are intended for all persons working on and using the dryer. We assume that all such persons are specialist personnel, e.g. fitters or electricians.

The tasks described in the section *Dryer Maintenance* must only be carried out by persons who have been trained by the manufacturer or a distributor.

Notes on the operating instructions

These operating instructions must be continuously available at the site where the dryer is used. We recommend to prepare a copy and to keep the same in a safe and freely accessible place next to the dryer. Keep the original document in a safe place.

For your own safety

The dryer has been built in accordance with the state of the art and the recognized technical safety regulations. Nevertheless, there is a risk of personal injury and damage to property when the dryer is used, if

- it is operated by non-qualified personnel,
- not used within its intended design specifications,
- is repaired or maintained incorrectly.

Note:

For your own safety and to prevent machine damage, please note the information and safety notes in these operating instructions when working with the dryer.

Intended use of the dryer

The dryer is solely intended for the purpose of drying compressed air and nitrogen (gaseous) in accordance with the Pressure Equipment Directive. Consultation with the manufacturer is required if the dryer is to be used in connection with other gases of fluid group 2.

Depending on defined conditions, it dries compressed air for industrial use. The compressed air must be free of aggressive water, oil and solid constituents.

Refer to *Technical data* on Page 66 for information on the defined conditions.

The dryer may only be operated in discontinuous operating mode when a start-up facility (pressure retention valve) is installed.

The dryer may be operated only in accordance with the data on the type plate and in accordance with the contractual conditions. Non-observance of the data given there is regarded as improper use.

Suspected misuse

In accordance with the Pressure Equipment Directive (PED), the dryer must not be used to dry potentially explosive, combustible or toxic gases of fluid group 1.

The dryer must not be misused as a climbing aid! Pipes, valves, and similar fittings have not been designed for such loads. They could fracture, tear off, or become damaged in another way.

Changes to the pressure vessels are not permitted.

General safety notes



For your own safety, when carrying out any work on the dryer comply with all applicable national safety regulations!



Risk of injury from escaping compressed air!

Never remove any parts of the dryer, or manipulate the same in any way, for as long as the plant is still pressurised! Suddenly escaping compressed air might cause serious injuries.

Before carrying out any work on the dryer, first depressurise the plant.



Hazard caused by exceeding the limit values!

The dryer may only be operated within the defined operating conditions. Exceeding the maximum permissible conditions can cause serious injuries and death.

The operating company must ensure the maximum operating pressure and permissible fluid temperature are not exceeded by installing corresponding safety devices.



Warning against sudden air ejection!

During expansion the pressure is released suddenly through the muffler:

- **A loud cracking noise occurs which can injure your hearing.**
- **Particles carried in the air flow act like bullets and can injure your eyes or skin.**

Always wear eye and ear protection, therefore, when you are in the vicinity of the dryer!



Attention! Start up dryer in discontinuous operating mode!

Discontinuous operation (cut-out mode) and correspondingly frequent dryer start-ups can cause excessively high flow rates in the dryer. Frequent pressure surges and excessive flow rates can damage the dryer as well as its valves and fittings.

A start-up device prevents high flow rates from occurring in the dryer even in the case of synchronised, automatic compressor start-up. For discontinuous operation it is therefore necessary to install a pressure retention valve downstream of the dryer.



Risk of falls!

The dryer must not be misused as a climbing aid! The components have not been designed for such loads and could fracture.

Personnel qualification

Only authorized and qualified specialist personnel may be tasked with the work on the dryer described in these operating instructions.

The operating personnel must have been trained by the manufacturer or a distributor.

Conversions and modifications

Without prior approval by the manufacturer, no conversions and modifications must be made to the dryer! Any non-approved modifications may restrict the operational safety of the dryer and cause damage to property or personal injury.

Handling desiccant

The desiccants are perfectly safe when in an unused condition. However, when filling and emptying the vessels with desiccants, increased dust generation may occur. Please comply with the following instructions:

- When filling desiccants into the vessels, wear a dust mask and eye protection!
- If a spillage occurs, any spilt desiccant must be taken up immediately. There is a risk of skidding!

Disassembly and disposal

Dispose of all parts of the dryer, the desiccant and all other operating in an environmentally responsible manner and in accordance with the current legal regulations.

Signs and hazard areas on the dryer

Signs and labels

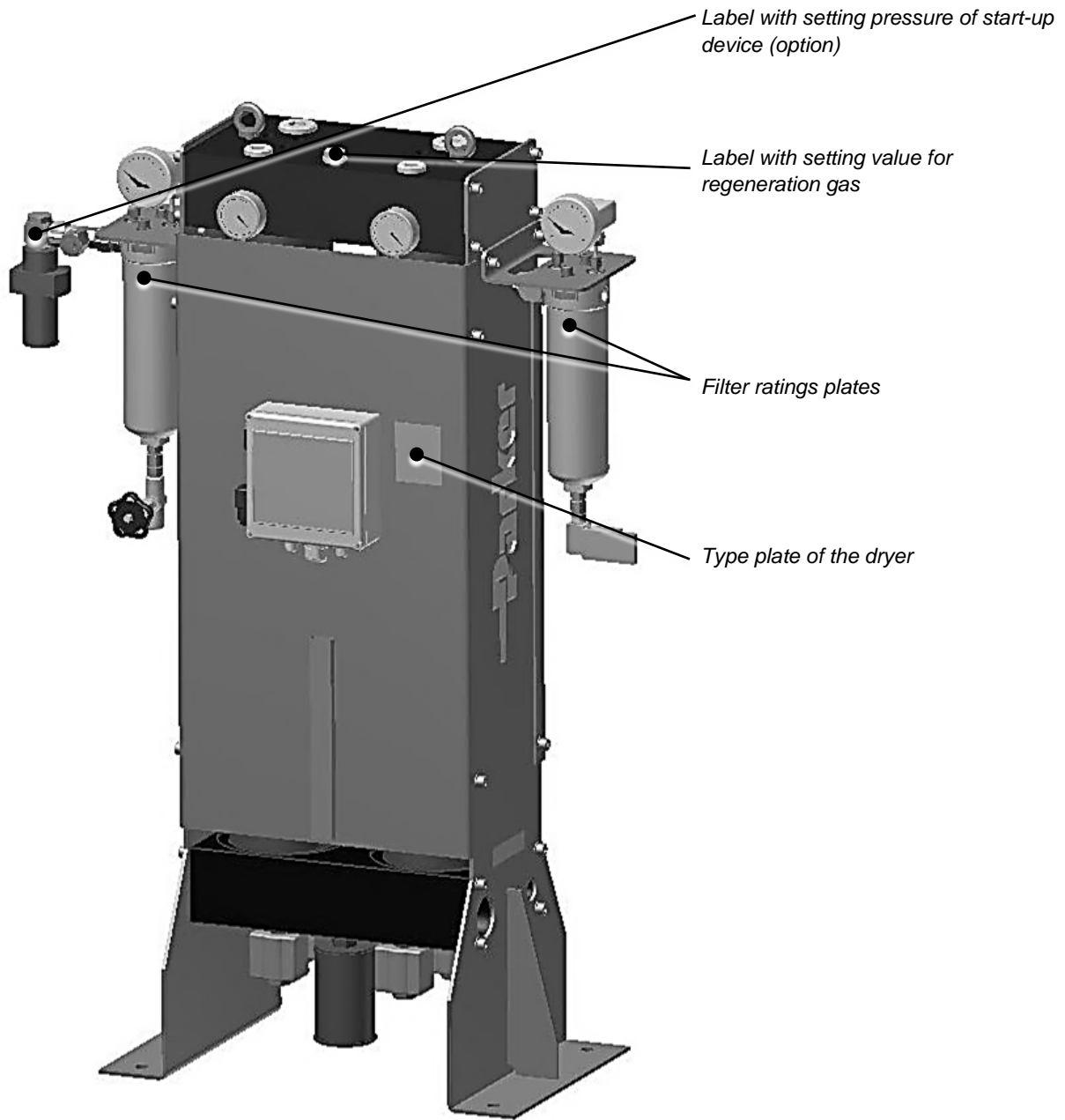



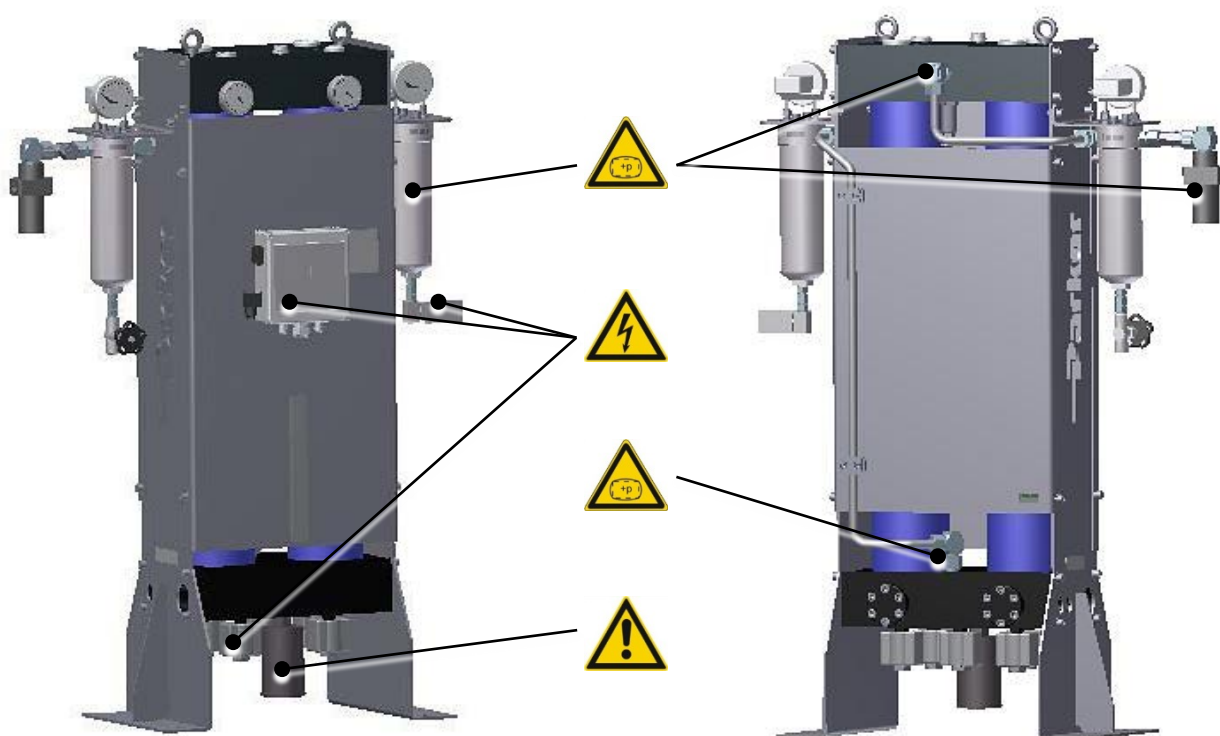

Front view

Please note these signs on the dryer. Keep them complete and always legible. Keep them complete and always legible.

Hazard areas on the dryer



Hazard area	Symbol in operating instructions
<p>Warning against hazardous electrical voltage</p> <p>Different parts of the dryer carry electrical current. These parts may be connected, opened, and maintained by authorized specialist personnel only.</p>	
<p>Warning against overpressure</p> <p>The entire dryer is under pressure. Before commencing any work, the plant must be depressurised.</p>	
<p>Warning against sudden air ejection</p> <p>When the vessels are depressurised, air flows suddenly out of the sound absorber:</p> <ul style="list-style-type: none"> ■ This causes a sudden loud cracking noise. ■ Due to particles carried in the air flow, there is a very considerable risk of eye injury. <p>When working on the dryer, always wear eye and ear protection equipment.</p>	 
<p>Risk of skidding</p> <p>When emptying and filling the vessels with desiccant, there is a risk of skidding caused by spilt desiccant.</p>	

Technical Description

Layout

Front view

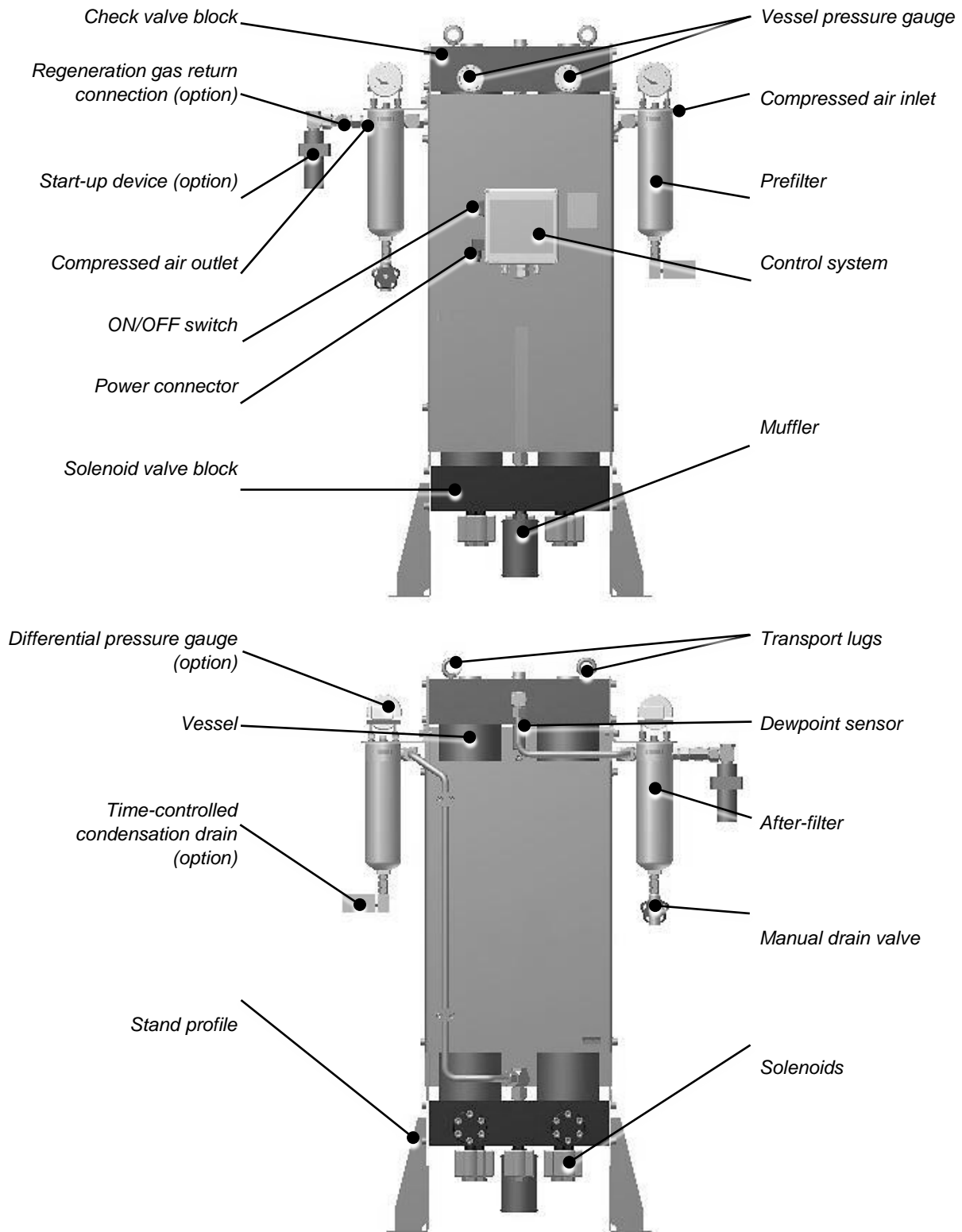

Function

The dryer dries the compressed air supplied by the compressor and makes it available for industrial use.

The installed prefilter and after-filter clean the compressed air supplied to the dryer and the compressed air from the dryer to the consumers.

The two vessels contain extremely porous desiccants by means of which humidity is removed from the compressed air and stored just as in a sponge. The stored moisture is further removed from the desiccants and then fed into the environment.

To this end, the two vessels alternate between different operating modes. Whilst in one vessel, compressed air is de-humidified (adsorption), in the other vessel the humid desiccant is prepared for another charge (regeneration). These two states, which run in parallel during compressed air preparation, are described below.

Adsorption

The moist and unfiltered compressed air delivered by a compressor is initially fed to the prefilter (coalescence filter) where solid and liquid particles are filtered out. The filtered components are expelled from the system via a condensation drain valve. The compressed air then flows through the pressurised absorption tower from the bottom to the top. In so doing, the desiccants dehumidify the air. The after-filter at the dryer outlet filters any remaining solids from the flow of compressed air to protect the downstream components. The dry compressed air is then routed via the piping system to the consumers.

Regeneration (running in parallel to the adsorption)

At the same time the other vessel is prepared for a renewed take-up of humidity. This process is called regeneration.

The regeneration is subdivided into three phases: expansion, dehumidification, and pressure build-up. If the dryer is operated in *dewpoint control* mode a further phase, i.e. standby phase follows regeneration.

Expansion phase

During the expansion phase the pressure in the vessel is released via the muffler down to ambient pressure within just a few seconds. The outflow of the compressed air becomes noticeable due to a sudden powerful flow noise at the muffler.

Dehumidification phase

Prior to being released into the pipe network, dried compressed air is bled by means of an orifice plate. This separate regeneration air flow is fed through the depressurised vessel.

The humidity stored in the desiccant is taken up by the air flow and expelled into atmosphere via the muffler.

Pressure build-up phase

After dehumidification the pressure in the regenerated hollow section vessel is built up to operating pressure, so that the switchover from regeneration to adsorption can take place at operating pressure level.

Switchover

When the desiccant in the adsorbing vessel has taken up a sufficient level of humidity, then the switchover between the vessels will be effected between the vessels. Following switchover, the above-described process is repeated, with the adsorption and regeneration now taking place in the respective different vessel.

Standby phase (only with the *dewpoint-sensing control*)

When in standby phase, the fully regenerated vessel is ready for absorption operation. The system is switched to this chamber, as soon as the measured dewpoint at the compressed air outlet has reached the set dewpoint value for switchover.

Standard equipment

Compressor synchronisation

The control system is equipped with a digital input for the synchronised operation with a compressor. This feature allows for synchronised and thus efficient dryer operation with discontinuous compressor operation, as the dryer can be operated independently of the compressor.

Dewpoint-sensing control

With the dewpoint-sensing control system, you can operate the dryer in fixed or variable cycles. In the fixed cycle, switchover is effected after a fixed time period (usually after 10 minutes). Changeover in the variable cycle depends on the charge of the desiccant and the dewpoint measured at the dryer outlet as well as the set changeover value. The adsorption time in the variable cycle is set to max. 60 minutes (see Page).

Available options

The following options are available for the dryer:

- Start-up device
- Condensation drain for prefilter
- Differential pressure gauge for up- and after-filters

Start-up device (also pressure retention valve)

If the dryer is operated in a depressurised compressed air system excessively high compressed air flow rates will occur in the dryer. These flow rates can damage the desiccant and cause increased wear of the dryer components. The pressure must therefore not be applied or relieved abruptly when starting up and shutting down the dryer.

A start-up device protects the dryer from excessively high flow rates as it only opens after reaching a preset minimum pressure of approx. 80%, thus maintaining adequate operating pressure in the dryer.

A T-piece is supplied with the start-up device, to which the regeneration gas return can be connected.

Time-controlled condensation drain on prefilter

The purpose of the condensation drains is to drain off the liquid collected in the prefilter. The time-controlled condensation drains drain off the liquid at defined time intervals.

Differential pressure gauge for up- and after-filters

The differential pressure gauge shows the pressure difference between the filter inlet and outlet. The degree of filter contamination is determined based on the differential pressure. If the differential pressure gauge is equipped with a reed contact, a signal will be output at a defined limit value.

Transportation, installation and storage



Danger due to incorrect transportation!

The dryer must be transported by authorized and qualified specialist personnel only. During transportation all applicable national regulations for accident prevention must be complied with. Otherwise there is a risk of personal injury.



Danger of toppling over!

The dryer has a very high centre of gravity. The dryer toppling over can cause serious injuries. Secure the dryer for transportation and while loading and unloading to prevent it toppling over.

- Dryers are delivered upright, bolted to a pallet (exceptions are possible for air or ship transportation).
- The position of the dryer centre of gravity is specified on the packaging.
- The openings in the dryer must remain closed off with plugs to prevent moisture getting into the dryer.
- Only use suitable and technically perfect lifting gear with a sufficient carrying capacity.

The manufacturer will not be liable for any damage caused by incorrect storage or incorrect transportation. Please note therefore the following instructions as well as the storage instructions on page 21.

If the packaging is undamaged

The undamaged packaging should be removed only at the final installation site, as it offers protection against any weather influences.

What to do in the case of transport damage occurring?

- ▶ Check whether only the packaging or the dryer itself were damaged.
- ▶ Inform the haulier immediately in writing of any damages.
- ▶ Also immediately contact your distributor for the purpose of reporting/registering the damage.



Attention!

A damaged dryer must not be taken into operation! Damaged components may lead to functional faults and possibly cause further damage.

Transporting the dryer to its installation site



Warning - lifting dryer contrary to instructions!
Lifting the dryer contrary to instructions can cause damage.
Lift the dryer only with the supplied lifting eyebolts!



Transport lugs

Transportation using lifting or forklift truck



Warning against damage to property!
The dryer is supplied upright on a pallet. Therefore always use a pallet truck or forklift truck to transport the dryer on the pallet.

- ▶ Secure the dryer on the lifting or forklift truck against sliding movements.
- ▶ Transport the dryer to its installation site.

Installing and anchoring the dryer

Requirements for the installation site

The conditions at the installation site have a large influence on the functional capability of the dryer and the service life of the desiccant. In order to ensure a mode of operation, which is as continuous as possible, and low maintenance, the installation site must meet the following requirements:

- The installation location must provide protection against the weather inside a building as well as against humidity (e.g., the accumulation of condensation).
- The ambient temperature must not drop below +1 °C (33.8 °F). If necessary, an auxiliary heater is to be provided.
- Heed the dryer's noise level when selecting the installation location (see Technical data on page 66).

- The installation area must be level, firm and vibration-proof. It must have the necessary carrying capacity for the weight of the dryer. The weight of the dryer is specified in the technical data section of the annex.
- The dryer should be installed with sufficient spacing at the top, sides, and rear, in order to be able to carry out maintenance work and change the desiccant without any hindrances.
The minimum required spacing is 1 m.

If in doubt, the installation site must be inspected by specialists. Contact your distributor should you have any questions relating to the installation location.

Setup

- ▶ Remove the packaging of the dryer.
- ▶ Check that the lifting eyebolts are secure in the holes in the top valve block.
- ▶ Attach suitable lifting gear to the transport lugs.
- ▶ Place the dryer at its installation site.

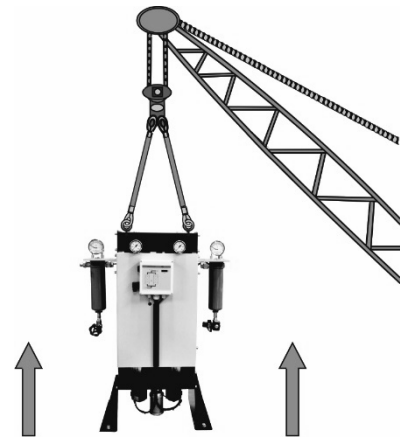

Transporting with crane

Anchoring the dryer

The upright stand profiles of the dryer are provided with pre-drilled anchorage bores.

- ▶ Use suitable attachment material to anchor the dryer to the floor (see figure).
- ▶ *In the case of vibrating floors:* place the dryer on suitable vibration dampers.

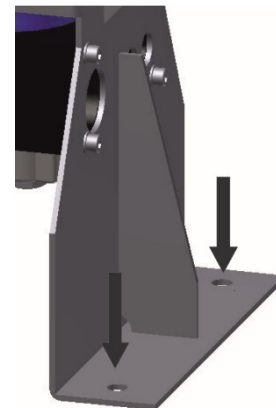

Holes on the base of the dryer

Storing the dryer

If the dryer is to be stored for an extended period of time, the storage location must meet the following conditions:

- The dryer must not be stored in the open air.
- The storage room must be dry.
- The storage room must be free from dust or the dryer must be covered by a protective sheet.
- The storage room must have an ambient temperature of at least +1 °C (33,8 °F).

In order to store the dryer proceed as follows:

- ▶ Take dryer out of operation as described on page 35.
- ▶ Ensure that the compressed air inlet valve installed by the owner, and the installed compressed air outlet valve installed by the owner, are both closed, and that the dryer is depressurised.
- ▶ Disconnect dryer from the compressed air system.
- ▶ Disconnect the dryer from the electrical power supply and all external lines.
- ▶ Use film material or similar to close the compressed air inlet apertures and compressed air outlet apertures on the dryer in order to protect them against contamination.
- ▶ If possible cover dryer with a protective sheet.

The dryer can now be stored for long periods.

Note:

If you wish to take the dryer back into service after an extended period of storage, please proceed as described for its first commissioning and start-up (see page 31).

Store drying agents

- ▶ Do not store drying agents in the open air.
- ▶ Protect drying agents against humidity.

Installation



Only authorized and qualified specialist personnel may carry out work on pipes and electrical systems.

As soon as the dryer has been set up at its installation location, you can install the compressed air infeed and outlet lines and make the electrical connections.

Recommended installation

We recommend the following installations to ensure reliable operation:

- **Bypass line**
A bypass line can be provided for when the dryer is not in operation (e.g. during maintenance) and the compressed air system still needs to continue operation. The bypass line is a "detour line", which allows the compressed air system to continue operating even whilst maintenance of the dryer is in progress. However, during this time the air is not dried but flows through the bypass line past the dryer and through to the actual loads. Filters in the bypass line are meaningful so that the actual loads are largely protected against dirt, water, and oil droplets even whilst maintenance is in progress.
- **Pressure retention valve**
A pressure retention valve is essential if the dryer is frequently operated in cut-out mode (discontinuous operation).
A pressure retention valve prevents excessively high flow occurring in the dryer or in the desiccant bed when starting up in a depressurised line system. A pressure retention valve allows the pressure in the dryer to build up slowly as the valve only opens on reaching a defined minimum pressure. The pressure retention valve is installed downstream of the dryer.
- **Compressed air tank**
The dryer uses compressed air during the regeneration process. When the compressor is in no-load state, this regeneration process cannot be completed without an external compressed air supply. The compressor stores compressed air in a compressed air tank. When the compressor is switched off, compressed air consumption is temporarily covered by this stored volume.
- **Regeneration gas return**
With the compressor in no-load state, the regeneration gas return is used to continue regeneration when the pressure at the dryer inlet drops and the regeneration started in a tower has not yet been completed. The corresponding expansion valve only closes when regeneration is completed. In standby mode, the control system remains on, and the dryer is ready for the next switchover, which is made as soon as the compressor is switched on.
- **Automatic condensate drain at prefilter**
An automatic condensate drain should be used to ensure the condensate is drained off from the prefilter at regular intervals.

Requirements for installation

For a correct installation of the the dryer following preconditions must be met on the part of the owner.

- Connections and lines for the infeed and outfeed of compressed air must be provided.
- A compressed air inlet valve as well as a compressed air outlet valve must be installed by the owner, so that the dryer can be installed and maintained in a depressurised condition.
- A pressure retention valve must be installed downstream of the dryer when the compressor is operated in cut-out mode (see Page 16). The pressure retention valve is set to 80% of the operating pressure.
- Steps must be taken to ensure that the dryer pressure does not drop below the minimum input pressure:
 - HDK-MT, pressure level 100 bar: min. 50 bar
 - HDK-MT pressure level 350 bar: min. 100 bar
- All pipes, couplings, and connections must have the correct diameter and match the operating pressure.
- A safety device must be provided in order to prevent the maximum permissible operating pressure and the permissible temperature being exceeded.

The data required to meet these preconditions are contained in the technical documentation attached in the annex.



Warning!

If the above preconditions are not complied with, a safe operation of the dryer cannot be assured. Also, the functionality of the dryer may be detrimentally affected.

Connect piping

In order to ensure that the dryer operates optimally, the dryer must be assembled into the compressed air system free of all stresses.

- ▶ Ensure before connection that all infeed and outfeed compressed air lines and valves are clean and undamaged.
- ▶ Check the bolt connections and retighten if necessary, as they could have worked loose during transportation.
- ▶ Remove plugs on the pressure inlet and outlet.



All piping must be free from any stress and tension whatever!

Pipes subject to stress may burst due to the load placed on them during operation. This may cause damage to property and personal injury.

- ▶ Use suitable pipes to connect the dryer to the compressed air system.
- ▶ The connection lines are to be installed at a slight incline in the direction of the prefilter.

- ▶ One shutdown valve is to be installed at both the compressed air inlet and outlet ends of the dryer.
- ▶ A pressure retention valve must be installed downstream of the dryer for discontinuous operation (cut-out operation) of the dryer.

Installing the electrical connection



Warning against electrical voltage

Only qualified specialist personnel may carry out work on the electrical system!

Installing the supply cable

The components of the dryer have been connected to the control cabinet at the factory. You only need to connect the control cabinet to the electrical supply cable.

The switchbox is provided with a connector where electrical power must be connected.

- ▶ Ensure that the cross-section of the electrical supply cable corresponds to the power rating of the dryer and the electrical voltage provided by the customer.
- ▶ Make the electrical supply cable to the dryer voltage-free.
- ▶ Secure the electrical supply cable to the dryer against switch-on.
- ▶ Undo bolt (1) on the connector and withdraw connector with seal from the switchbox.
- ▶ Use a suitable tool to remove the terminal block from the connection box.
- ▶ Undo the PG union and pull the cable through the aperture (3). The exposed phase ends should not be longer than 35 mm max.

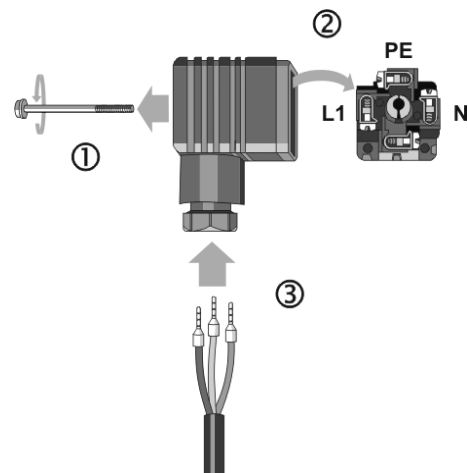

Connect electrical cable to device adapter

- ▶ Now make the cable connection as follows:
 - Earth to terminal PE
 - L1 to terminal 1
 - N to terminal 2

Terminal 3 is not used.

- ▶ Fit terminal block into the connector and use bolt to remount the connector with seal on the switchbox.
- ▶ In all phases the dryer must be protected against short circuits by means of fuses.
- ▶ In order to relief cable strain, re-tighten the PG union.

Connecting the external signalling lines

In respect of compressor synchronization

The control system is equipped with a digital input as standard for compressor synchronisation. Regeneration of the dryer during compressor synchronisation is controlled with the switch S1 on the pc-board of the control system (for switch S1 see Fig. below).

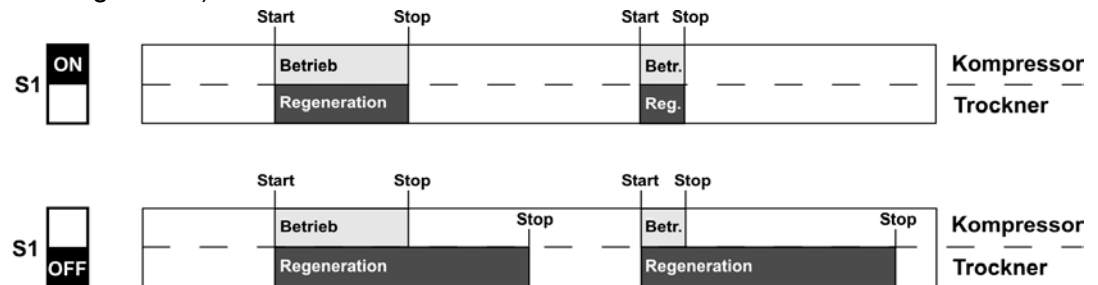

To install the external lines, proceed as follows:

- Connect the signalling line to the potential-free busbar connection of the compressor to terminals 1 and 2 on the control board (see circuit diagram).

Regeneration in compressor synchronisation mode

Dryers are delivered with the switch S1 set to position OFF at the factory

If switch S1 is in the OFF position, any regeneration process which has been started, is always continued until completed.

If the switch S1 is in the ON position, dryer regeneration will stop when the compressor stops. On restarting the compressor, regeneration will continue from the point at which it was interrupted. An interruption in regeneration is practical only for short compressor no-load times.

It is recommended to complete regeneration for longer compressor no-load times. A regeneration gas return facility is required to remove moisture from the desiccant.

Operating and control elements

ON/OFF switch

The ON/OFF switch (2) is located to the side of the switch box and above the mains plug (1, see figure):

- If it is set to 0, the power supply is disconnected and the dryer is switched off. The main valves are open when de-energized. This means the deactivated dryer is open in main flow direction.
- If the switch is set to **I**, the dryer is switched on and begins to operate in fixed cycle mode (i.e. time-controlled).
- If the switch is set to position **II**, the dryer is switched on and begins to operate
 - with compressor synchronisation
 - in variable cycle mode (i.e. dew-point-controlled).

Position **II** is only relevant for operation with *compressor synchronisation* and/or *dewpoint-sensing control*.

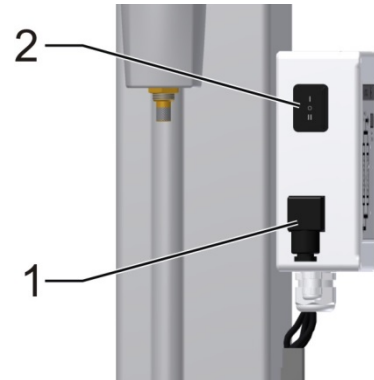

Switch box with ON/OFF switch

Display panel

The display panel at the switch box is equipped with LEDs (light emitting diodes) and a digital display, indicating the operating status of the dryer:

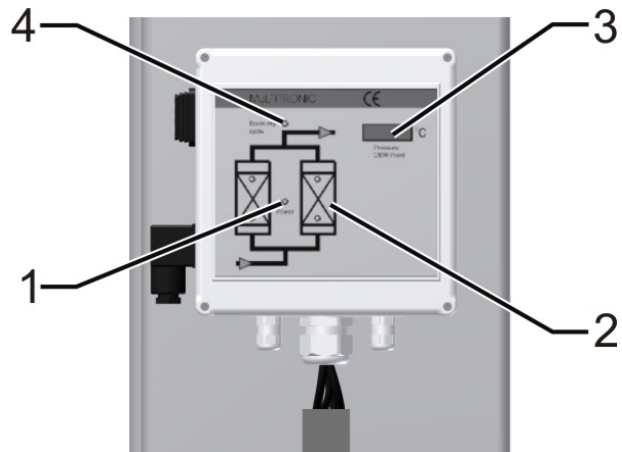

Display panel at the switch box

LED Power (1)

LED is on when dryer is switched on.

Flow diagram (2)

The current operating phases of the dryer are indicated by means of 4 LEDs:

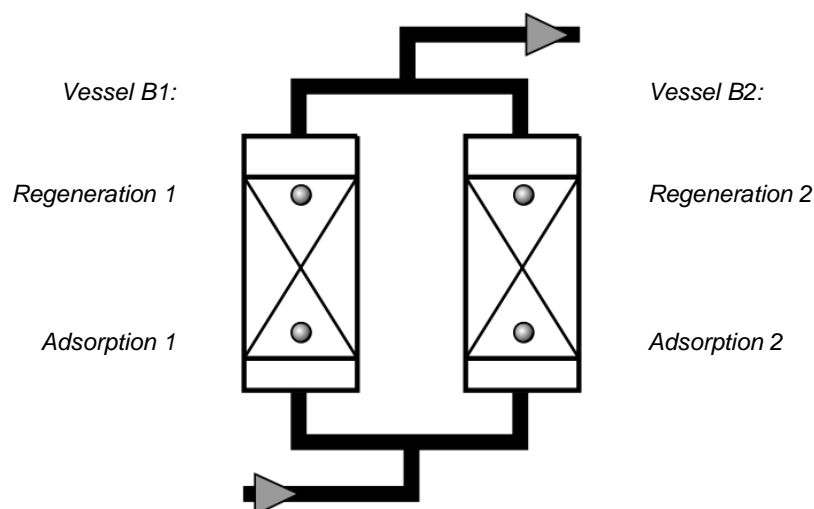

Depending on the operating phase, the following LEDs might be on simultaneously:

*Adsorption B1 and regeneration B2 or
regeneration B1 and adsorption B2.*

Digital display (3)

The digital display shows the individual programme steps and the respective remaining time. For details regarding the sequence of the individual processing steps and their duration, please refer to the logic control diagram, page 71.

Display		Description
2	215	Default display: The figure to the left indicates the current processing step; the figure to the right shows the remaining time in seconds. In this example, step 2 is being completed, whereby there are 215 seconds remaining.
SEr.		The <i>SEr.</i> display appears after every 8000 operating hours. (service) is displayed for periods of 1 minute, alternating with the default display. Notify the instructed service personnel, as a routine service is now due.
- 25		With the <i>dewpoint-sensing control</i> option, the display shows the currently measured dewpoint instead of the default data. The range of display is -100 °C (-148 °F) to +20 °C (68 °F). If the measured dewpoint exceeds the preset alarm limit (5 °C (41 °F) above the switchover value), the displayed dewpoint value is flashing.

With the *dewpoint-sensing control*, the following error messages might be displayed:

Display	Cause
+20	■ Upper measuring range limit exceeded
999	■ Dewpoint sensor defective
sens or -999	■ Dewpoint sensor not powered ■ Cable defective ■ sensor defective
SEr.	The <i>SEr.</i> display appears after every 8000 operating hours. (service) is displayed for periods of 1 minute, alternating with the default display. Notify the instructed service personnel, as a routine service is now due.

For instructions on how to eliminate faults, see chapter *Störungen erkennen und beseitigen*

LED Economy cycle (4)

The diode lights up when the dryer is switched on and in the standby phase and no regeneration air is required.

Pressure gauges

Pressure gauges are assigned to both vessels and show the operating overpressure. The operating overpressure indicates the operating phase of the relevant vessel:

- During adsorption the pressure gauge should indicate the nominal operating overpressure.
- During regeneration the indication of the pressure gauge on the regenerating vessel
 - should decrease in the expansion phase from operating overpressure to 0 bar overpressure,
 - indicate an overpressure of 0 bar in the dehumidification phase.

If the overpressure does not drop to 0 bar after a vessel has been depressurised, the vessel contains residual pressure, or “back pressure”. Back pressure can also cause an increase in noise on the sound absorber.

Commissioning



Warning against sudden air ejection!

During expansion the pressure is released suddenly through the muffler:

- A loud cracking noise occurs which can injure your hearing.
- Particles carried in the air flow act like bullets and can injure your eyes or skin.

Always wear eye and ear protection, therefore, when you are in the vicinity of the dryer!



Risk of injury from escaping compressed air!

Never remove any parts of the dryer, or manipulate the same in any way, for as long as the plant is still pressurised! Suddenly escaping compressed air might cause serious injuries.

Before carrying out any work on the dryer, first depressurise the plant.



Caution when starting the dryer!

Pressure surges can occur if pressure builds up too fast. Pressure surges can damage the dryer as well as its valves and fittings. Therefore, only switch on the dryer when the full operating pressure is shown on both pressure gauges.



Caution when starting up the dryer!

The required dewpoint can only be reached with sufficient regeneration of the desiccant. The dryer should therefore be operated for at least 12 cycles after start-up to ensure the desiccant bed is evenly regenerated.



Attention! Start up dryer in discontinuous operating mode!

Discontinuous operation (cut-out mode) and correspondingly frequent dryer start-ups can cause excessively high flow rates in the dryer.

Frequent pressure surges and excessive flow rates can damage the dryer as well as its valves and fittings.

A start-up device prevents high flow rates from occurring in the dryer even in the case of synchronised, automatic compressor start-up. For discontinuous operation it is therefore necessary to install a pressure retention valve downstream of the dryer.

Note:

You can arrange for your distributor to carry out the commissioning and have your personnel trained by the manufacturer.

Requirements for initial start-up

For the first start-up the following preconditions must have been met:

- The line network must be kept free of contamination.
- All shutoff valves and customer-installed compressed air inlet and outlet valves are closed.
- The dryer is correctly sited and installed.
- Check all unions and bolt connections as well as the terminals in the control cabinet for secure seating; re-tighten if necessary.

Checks before start-up

Ensure that

- all pipe, cable and bolt connections on the dryer have been retightened,
- no pipes chafe against body edges,
- all mountings are perfectly secure,
- the electrical connections are in safe contact and in good condition,
- owner-end and pressurised parts such as safety valves or other devices are not blocked up by dirt or paint,
- all compressed air system parts which are pressurised (valves, connections etc.) are free from wear symptoms and defects.

Dryer settings

Setting times of the operating phases



Warning!

The factory settings on the control board in the switch box must not be changed on any account without prior approval by the manufacturer.

Safe operation of the dryer cannot be guaranteed if the factory settings are changed. Also, the functionality of the dryer may be detrimentally affected.

In its standard version the dryer is delivered with a time-dependent control system. The phase sequence occurs in a fixed cycle.

With the *dewpoint-sensing control* the dryer can also be operated at variable cycles (depending on the dewpoint).

The following table provides information on the duration of the individual phases.

Phase duration	Fixed cycle	Variable cycle
Adsorption	10 min	60 min, maximum
Regeneration, total	10 min	10 min
– of which: expansion time	~ 0.2 min	~ 0.2 min
– of which: dehumidification time	~ 8 min	~ 8 min
– of which: pressure build-up	~ 2 min	~ 2 min
Standby	—	~ 50 min, maximum

Emergency shutdown

In the event of an emergency, shut down the dryer as described on page 35.

Start up dryer

- The more powerful the dryer is, the more noise may be generated during operation. Therefore, the owner must provide suitable protective equipment (e.g. ear protection).
- Only operate the dryer within the permissible limits. By operating the dryer in conditions for which it has not been designed, functional faults may be caused.
- Depending on the size of the dryer and the compressed air network and the respective legal requirements in your country, it may be necessary to perform initialisation according to the directive for pressure equipment.
- Check the dryer regularly for externally visible damage and defects. Any changes, even in its operating behaviour, must be reported immediately to the competent office or person.
- In the event of an emergency or if a safety-relevant disruption occurs (e.g. escaping compressed air, defective component), the dryer must be shut down immediately as described in the section *Trockner drucklos machen und außer Betrieb nehmen* on page 35). The dryer may only be restarted after all defects have been eliminated.
- Before start-up, ensure that no tools or other foreign parts have been left lying in a part of the dryer where they might pose a hazard to the dryer being started up.

Open compressed air supply and switch on dryer

For start-up, please proceed in the sequence shown here.

- ▶ Ensure that the compressed air inlet and outlet valves installed by the owner are closed.
- ▶ Ensure that the compressed air system upstream of the dryer is pressurised. If necessary, pressurise (switch on compressor).



The ambient temperature must not drop b

Make sure sudden pressure build-up is avoided! If pressure builds up too fast, this may cause damage to the dryer. Therefore, the compressed air inlet valve must always be opened quite slowly!

- ▶ Installation area
- ▶ Check that the full operating pressure is shown on both pressure gauges.
- ▶ Switch on dryer: to this end, set the ON/OFF switch to **I**.

If the dryer is taken into operation for the first time, or after a change of desiccant, the following intermediate step is meaningful. When restarting (after a few hours), the following intermediate step can be skipped.

Operating the dryer for the first time (or after a change of desiccant) separately
Depending on the transportation and storage conditions, the desiccant in the vessels can already be loaded with humidity from the environment. At each first start-up it makes sense therefore to operate the dryer from some time separately from the compressed air system. This causes the desiccant in each vessel to be regenerated repeatedly and thus to be prepared optimally for the take-up of humidity.

Note:

Depending on the pressure dew point to be achieved, we recommend to operate the dryer at first start-up without compressed air consumption:

- for at least 4 hours at a pressure dew point of -25 to -40 °C
- for approx. 3 to 5 days at a pressure dew point of -70 °C.

If you wish to take the dryer into operation in accordance with our recommendation, proceed as follows:

- ▶ Ensure that the compressed air outlet valve installed by the owner is closed.
- ▶ Keep the compressed air outlet valve closed for the time period recommended above.

Then the dryer can be taken into service in the compressed air system as described in the following section:

Operate dryer immediately in the compressed air system

- ▶ Ensure that the compressed air system downstream of the dryer is pressurised or that a start-up device (option, see page 16) was installed downstream of the dryer.
This is even more important the larger the compressed air system downstream of the dryer and the more often the compressor operates in cut-out mode.



The ambient temperature must not drop be

Avoid a sudden drop in pressure in any circumstance! If pressure drops too fast, this may cause damage to the dryer. Therefore, the compressed air outlet valve must always be opened quite slowly!

- ▶ Slowly open the compressed air outlet valve installed by the owner. Observe the vessel pressure gauge of the pressurised vessel. The pressure should not drop below the operating pressure (if poss.). If necessary, keep the compressed air outlet valve in a slightly open position until the compressed air system downstream of the dryer has filled up completely; only then should the valve be opened fully.

The dryer has then be taken into operation within the compressed air system.

In the event of a fault

In the event of an emergency or if a safety-relevant disruption occurs (e.g. escaping compressed air, defective component), the dryer must be shut down immediately as described in the section *Shutting down and restarting the dryer* on page 35).

Then proceed as follows:

Remedy fault

- ▶ Look up possible cause of the fault, and how to remedy the same, in the table on page 60.
- ▶ Remedy fault.
- ▶ Repeat the start-up procedure.

Recommended operating modes in the individual phases

On successful conclusion of initial operation, the dryer can be operated in different modes:

- Compressor synchronisation control and
- Dewpoint-sensing control

Compressor synchronisation mode as well as dewpoint-sensing control can only be started together. Compressor synchronisation has priority over dewpoint-sensing control.

Compressor synchronisation

If compressor synchronisation is enabled, the dryer can only be operated in conjunction with the compressor.

As soon as the compressor is switched off, the dryer is automatically set to standby mode. In standby mode, the dryer remains switch on and is operational as soon as the compressor is switched on again. For information on regeneration see Page .

With dewpoint-sensing control

Dryers equipped with dewpoint-sensing control operated in variable cycle mode, based on the measured dewpoint of the dried air at the compressed air outlet. As soon as a certain dewpoint is reached, as the desiccant in the absorbing vessel is saturated, the vessels are switched. The dewpoint at which a switchover is made is preset at the factory.

When *should* I change cycle mode?

Cycle changes should be made during the pressure build-up phase and prior to switchover; during this phase, the pressure in both towers is virtually at the same operating pressure so that fast pressure build-up is prevented when the towers are switched over.

During this period, only the adsorption LED is on in the diagram, and the digital display shows step 4 or step 9 for the duration of 1 minute (see logic control diagram; not displayed with dewpoint sensing).

During the pressure build-up phase, only one diode *Adsorption B1/B2* lights on the flow diagram and both towers are at the same operating pressure.

- ▶ Set the ON/OFF switch to position **II**.

The programme continues the cycle.

Monitoring dryer operation

The dryer operates fully automatically. However, you should carry out the regular checks described in the Chapter *Maintenance and repair of the dryer*.



Warning against sudden air ejection!

During expansion the pressure is released suddenly through the muffler:

- **A loud expansion noise is caused which may damage your hearing.**
- **Particles carried in the air flow act like bullets and can injure your eyes or skin.**

Always wear eye and ear protection, therefore, when you are in the vicinity of the dryer!

With dewpoint-sensing control

Display of dewpoint

The digital display at the front of the switch box shows the currently measured dewpoint. The range of display is -100 °C (-148 °F) to $+20\text{ °C}$ (68 °F). The dewpoint at which a switchover is made is preset at the factory.

- ▶ After commissioning or extensive maintenance work, check the dewpoint display at the dryer.

Under certain circumstances, the desired dewpoint is only reached after prolonged operation.

Shutting down and restarting the dryer

In the following cases, the dryer must be fully shut down and depressurised:

- In the event of an emergency or malfunction
- For maintenance
- For disassembly



Warning - damage to dryer after power failure!

The two main valves (V1/V2) open in the event of the power failing. This can cause sudden pressure equalisation if one tower is pressurised while the other is regenerating. This pressure equalisation between the towers can damage the valves and the desiccant bed.



The dryer may not be shut down correctly after the power supply has been interrupted or in the case of emergency. In this case the two inlet valves are open and both expansion valves are closed.

If malfunctions occur after power failure or an emergency (e.g. poor dewpoint), a 12-month maintenance routine will be required. The desiccant and the dust screen should also be checked.

Note:

If the unit is equipped with a compressor synchronisation system, first switch off the compressor and then wait until the dryer has reached the standby phase before switching it off with the ON/OFF switch.

This ensures that the regeneration cycle is completed, and that the pressure in both vessels is at the same level.

As soon as the dryer is switched on again, the programme continues the cycle from the point at which it has been stopped.

Shutting down and depressurising the dryer

Disconnect dryer from the compressed air system.

- ▶ Close the pressure outlet valve installed by the operator.
- ▶ Close the pressure inlet valve installed by the operator.

Depressurise dryer

- ▶ Leave the dryer switched on until each vessel has run through an expansion phase.

The vessels are relieved from pressure one-after another due to the expansion phase.

- ▶ Check the pressure relief of the dryer on both pressure gages. They should indicate "0" bar.

Disconnect voltage supply

- ▶ Switch off the dryer by setting the ON/OFF switch to position 0.

If work is to be carried out on the electrical system

- ▶ Depressurise and shut down the dryer, following the instructions in the above chapter.



Risk of injury due to voltage-carrying parts!

The electrical supply cable and external power lines are live even after the dryer is switched off and, in the event of body contact, may cause serious injury! Before carrying out any work on the electrical system, the electrical supply cable and all external power lines must be made voltage-free!

- ▶ Make the electrical supply cable to the dryer voltage-free.
- ▶ Secure the electrical supply cable to the dryer against switch-on.

Re-start

Depending on the fittings installed by the operator and the actual pressure conditions, the unit might have to be restarted at operating pressure. The following general rules apply:

- The deactivated dryer is open in main flow direction.

If compressed air system and dryer have remained at operating pressure

- ▶ Ensure that the compressed air inlet valve (provided by the operator) is open.
- ▶ Set ON/OFF switch to **I**.
The program continues the cycle from the point at which it was interrupted..



The ambient temperature must not drop be

Avoid a sudden drop in pressure in any circumstance! If pressure drops too fast, this may cause damage to the dryer. Therefore, the compressed air outlet valve must always be opened quite slowly!

- ▶ Slowly open the compressed air outlet valve installed by the owner. Observe the vessel pressure gauge of the pressurised vessel. The pressure should not drop below the operating pressure (if poss.).
 - In no pressure retention valve is installed:
Keep the compressed air outlet valve in a slightly open position until the compressed air system downstream of the dryer has filled up completely; only then should the valve be opened fully.

The dryer is now back in operation and is working fully automatically.

If compressed air system and dryer have not remained at operating pressure

- ▶ If disconnected, reconnect the voltage supply of the dryer.
- ▶ Pressurise and switch on the dryer as described in the section *Open compressed air supply and switch on dryer* on page 31.

The dryer is now in operation again and operates fully automatically.

Maintenance and repair of the dryer

In order to allow maintenance work on the dryer to be carried out efficiently and without danger for maintenance personnel, you should comply with the following instructions.

Notes on maintenance



Attention!

All maintenance work must be completed by authorised and qualified specialist personnel trained by the manufacturer or his distributor.



Danger!

There is a very considerable risk of personal injury, when carrying out work on the activated and pressurised dryer.



Before commencing any maintenance tasks always shut down the dryer as described on page 35, *Trockner drucklos machen und außer Betrieb nehmen!*



Warning - injury hazard posed by backpressure!

When relieving pressure, swollen seals can cause backpressure. The outflow of compressed air can cause injuries.

Only slacken off screw connections and loosen components with great care and slowly.

Allow the system to decompress over night (several hours) before carrying out maintenance work.



Warning against sudden air ejection!

During expansion the pressure is released suddenly through the muffler:

- A loud cracking noise occurs which can injure your hearing.
- Particles carried in the air flow act like bullets and can injure your eyes or skin.

Always wear eye and ear protection, therefore, when you are in the vicinity of the dryer!

Note:

For an inspection of the pressure vessels, the desiccant must be removed.

- Check the dryer regularly for externally visible damage and defects. Any changes, even in its operating behaviour, must be reported immediately to the competent office or person.
- Bolt connections must be undone with care! Note ram pressure values! Otherwise emerging media may cause personal injury.
- Following maintenance work, always check all flange and bolt connections for leakage and secure seating.

- Never leave tools, loose parts or cloths in, at or on the dryer.
- Only use replacement parts that are suitable for the relevant function and meet the technical requirements stipulated by the manufacturer. This is always the case, if you use original replacement parts only.

Regular maintenance intervals

The table provides an overview of the maintenance work to be carried out. The following pages describe some of these tasks. Maintenance work requiring the dryer to be largely disassembled is not described. We recommend to have this work to be performed by authorised specialists.

Component	Maintenance task to be carried	Maintenance interval			
		weekly	12 months	24 months	see page
Complete dryer	Carry out visual and function checks.	●			41
Vessel pressure gauge	Check dam pressure.	●			41
Muffler	Clean muffler, replace if necessary.		●		44
Dew point sensor	Replace.		●		42
Filter elements and O-rings	Replace.		●		
Inlet and expansion valves (V1-V4)	Replace.		●		47
Pilot valves (Y1-Y5)	Replace.			●	42
Desiccant, dust sieve	Replace.			●	47
Seals in tower - pistons and connection sockets	Replace.			●	48
Check valves (RV5/RV6)	Replace.			●	51
Check valves (RV1-RV4)	Carry out maintenance as required				55
Coils of pilot control units					57

Note:

To assure perfect maintenance and reliable operation, we recommend concluding a maintenance contract. Contact your distributor.

Instructions for use of the dongle

If the message **SEr.** is displayed on the display of the Multitronic controller, the dryer is due for servicing. The message appears, flashing every 60 seconds, once the preset number of operating hours (e. g. 8000 oh) has been reached. After maintenance has been carried out, you can use the dongle to reset the counter to 0 and delete the message from the display. A dongle is enclosed with every service kit. Each dongle can only be used once.

- ▶ Switch off the controller. Caution! The electric line is still live. Do not touch live parts!
- ▶ Open the lid to the Multitronic controller. The circuit board is housed underneath it.
- ▶ Slot the dongle into the dongle interface *X9 PC*.
- ▶ Press and hold the reset key *S3*.
- ▶ Switch on the controller. The following appears in the display:

for a short time then flashing	0.SET OFF
-----------------------------------	----------------------------

The service counter is then reset to 0.

If the following appears in the display:

for a short time then flashing	FAIL OFF
-----------------------------------	---------------------------

this means that the dongle has already been used once and cannot be used again.

- ▶ Switch off the controller again and remove the dongle.
- ▶ Dispose of the unusable dongle and use a new one.

HDK-MT special tool kit

We recommend that you use the special tool kits Toolkit-1, Toolkit-2 and Toolkit-3 to ensure safe and successful maintenance of the HDK-MT series.

The HDK Toolkit-1 is required for all relevant maintenance jobs on the valves of the HDK-MT series. The Toolkit-1 contains special tools required for 12/24 month maintenance.

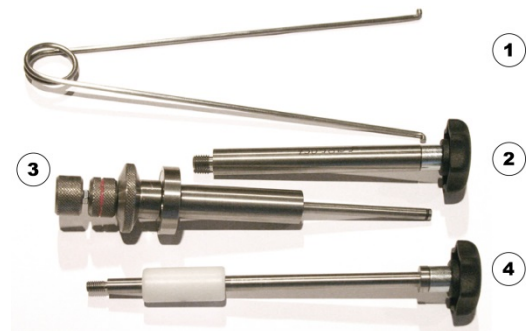

Toolkit-1

The HDK Toolkit-2 is required to successfully change the desiccant safely. This toolkit is required for easy and safe removal/installation of the tower piston.

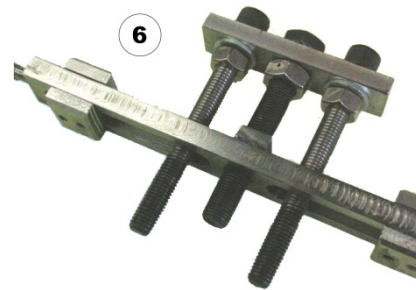

Toolkit-2

The HDK Toolkit-3 is required to easily and safely releasing the tower connection piece from the valve blocks.

Legend to special tools

Item	Description
1	Hook puller
2	Valve seat extractor-1
3	Check valve puller
4	Valve seat extractor-2
5	Gauge
6	Piston puller
7	Connection piece puller

Perform a weekly visual inspection

Clean dryer

- ▶ Remove any loose dust by means of a dry cloth, and, if required, also by means of a moist and well wrung cloth.
- ▶ Clean the surfaces of the controls and the signs with a moist well wrung cloth.

Carry out visual and function check on the complete dryer

- ▶ Check dryer for external damage or unusual noise generation.
- ▶ Duly eliminate any defects found.

If message **SEr.** is displayed, a routine service must be completed:

- ▶ Notify the instructed service personnel.

The connection line

If, following depressurisation of a vessel, e.g. after the expansion phase, the overpressure has not decreased to 0 bar, then there is a residual pressure, designated as dam pressure, in the vessel.

- ▶ Check for dam pressure: if the dryer functions correctly, the respective pressure gauge indicates 0 bar. Then there is no dam pressure.

If the dam pressure is greater than 0 bar:

- ▶ Depressurise the dryer and shut it down (see page 35).

Dam pressure can be caused by:

- a blocked muffler,
- a blocked dust sieve and
- desiccant which is too old.

The respective necessary maintenance measures are described in the following sections.

The connection line

If, following depressurisation of a vessel, e.g. after the expansion phase, the overpressure has not decreased to 0 bar, then there is a residual pressure, designated as dam pressure, in the vessel.

- ▶ Check for dam pressure: if the dryer functions correctly, the respective pressure gauge indicates 0 bar. Then there is no dam pressure.

If the dam pressure is greater than 0 bar:

- ▶ Depressurise the dryer and shut it down (see page 35).

Dam pressure can be caused by:

- a blocked muffler,
- a blocked dust sieve and
- desiccant which is too old.

The respective necessary maintenance measures are described in the following sections.

Draining condensate

Depending on the amount of accumulated condensate, open the condensate drain at regular intervals to drain off the condensate.

Check operation of an automatic condensate drain as described in the condensate drain manual.

Maintenance work to be completed every 12 months



Danger!

There is a very considerable risk of personal injury, when carrying out work on the activated and pressurised dryer.

Maintenance tasks should only be carried out with the system switched off and depressurised.

Replace dewpoint sensor

To ensure precision dew point measurement, it is recommended to replace the dew point sensor every year.



Take care not to damage the sensor!

The dew point sensor is a sensitive measuring device. It can be damaged if subjected to forceful vibrations or shocks. Therefore, please handle the dew point sensor with great care at all times.

Replace the sensor as follows:

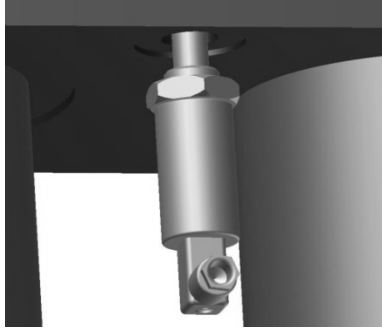
- ▶ Depressurise the dryer and shut it down (see page 35).
 - ▶ Loosen the screw at the adapter and disconnect signal cable with the adapter.
 - ▶ Remove dewpoint sensor from the sensor cell by turning the nut.
 - ▶ Take the new dewpoint sensor from the box, remove the protective caps and screw it into the sensor chamber.
 - ▶ Plug in connector and secure with screw.
- 
- Dewpoint sensor*
- ▶ Check that all screw connections are tight.
 - ▶ If no other maintenance work is to be carried out: Restart the dryer (see page 36).
 - ▶ Place the protective caps (4, 5) onto the old dew point sensor and dispose of it in accordance with the applicable regulations.

Note on changing the connecting cable:

The connecting cable between the dewpoint sensor and control system must be shielded to ensure trouble-free operation and reliable measured values!

Renew filter elements on the filters

With a differential pressure greater than 0.6 - 0.8 bar or after 1 year at the latest, the filter elements must be renewed.

- ▶ Depressurise the dryer and shut it down (see page 35).



Warning - lower section of filter housing may drop off!

Depending on the size, the weight of the bottom filter section may be 12 kg! Secure the dead weight of the filter bottom section using a suitable protective device.

- ▶ Place the open-ended spanner on the square on the bottom section of the filter and unscrew the bottom section (see figure opposite).
- ▶ Unscrew the filter element clockwise from the threaded rod.
- ▶ Clean the filter mount and the thread of the housing section.
- ▶ Replace both O-rings in the housing (see figure below).
- ▶ Lightly grease the thread area and the O-rings with the recommended assembly paste.
- ▶ Screw the new filter element including seal onto the threaded rod.
- ▶ Screw the filter bottom section into the top section by 2 to 3 thread turns. In doing so, observe the ease of motion of the thread.
- ▶ Screw the filter bottom section until you can feel the resistance against the upper O-ring.
- ▶ A gap as thin as paper must remain between the top and bottom section.
- ▶ Close condensation drain if necessary.
- ▶ Open the supply line to the filter.
- ▶ Restart dryer (see page 36).
- ▶ Check the filter for tightness.
- ▶ Dispose of filter elements accordingly.

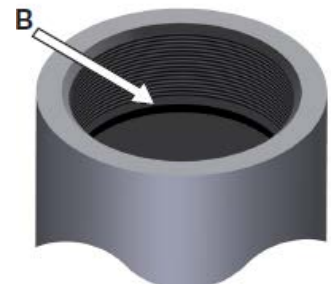

Changing filter elements

Recommended assembly paste: Rivolta GWF

Cleaning muffler



Hazard caused by blocked muffler!

Blocked mufflers can cause a dangerous overpressure to build up which may cause the mufflers to burst. Flying fragments may cause personal injury and damage to property.

If the muffler becomes blocked, a dam pressure is generated which in extreme cases may cause the muffler to burst. A dam pressure can also be noticed by the increased noise development at the muffler.

- ▶ Depressurise the dryer and shut it down (see page 35).
- ▶ Remove muffler from solenoid valve block.
- ▶ Clean muffler, replace if necessary.
- ▶ Fit new muffler in the block and hand-tighten.
- ▶ Check that all screw connections are tight.
- ▶ If no other maintenance work is to be carried out: Restart the dryer (see page 36).

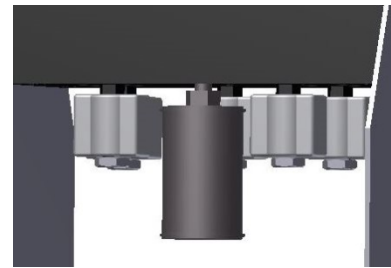

Undo muffler

Replacing inlet/expansion valves V1 - V4

The main valves in the solenoid valve block are wearing parts and should be replaced every 12 months. Refer to the flow diagram on Page 73 for the layout of the solenoid valve block.

Note:

We recommend removing the entire solenoid valve block where the dryer is difficult to access and for quicker maintenance.

In this way the maintenance work can be conveniently performed on a workbench.

Depending on the installation situation and dryer model, however, it may be necessary to remove and tilt the entire dryer for this purpose.

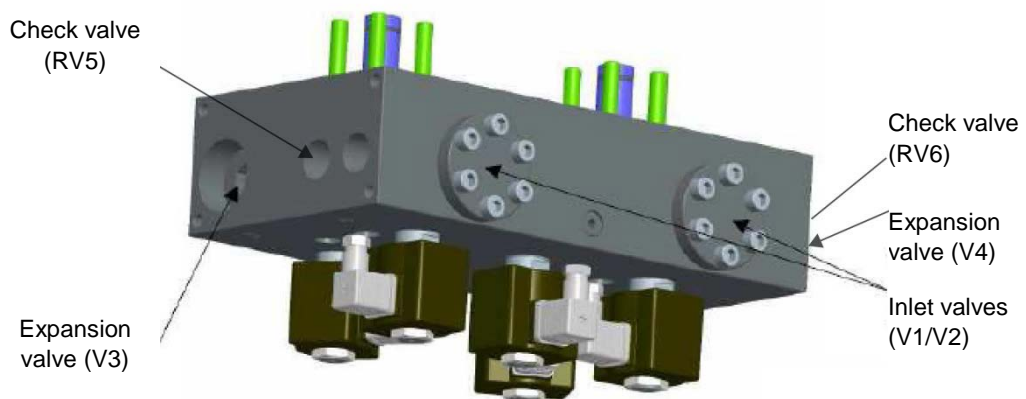

Solenoid valve block

Replacing inlet valves V1 / V2



Warning - injury hazard posed by backpressure!

When relieving pressure, swollen seals can cause backpressure. The outflow of compressed air can cause injuries.

Only slacken off screw connections and loosen components with great care and slowly.

Allow the system to decompress over night (several hours) before carrying out maintenance work.

- ▶ Depressurise the dryer and shut it down (see page 35).

- ▶ Undo the cylinder screws (10).

Take care during the next step!

There is a compression spring (7) behind the flange (9). When removing the flange, the spring may relieve and jump out of the holder.

- ▶ Remove the flange (9) carefully.
- ▶ Pull out the compression spring (7) and piston (4).
- ▶ Check the valve seat (2) for damage, replace if damaged.
- ▶ Carefully grease O-ring (3) and fit in valve seat.
- ▶ Fit valve seat (2) in valve plate (1).
- ▶ Insert piston (4) in the hole while pressing the piston ring (5) together by hand so that the piston can be moved a little in the housing.

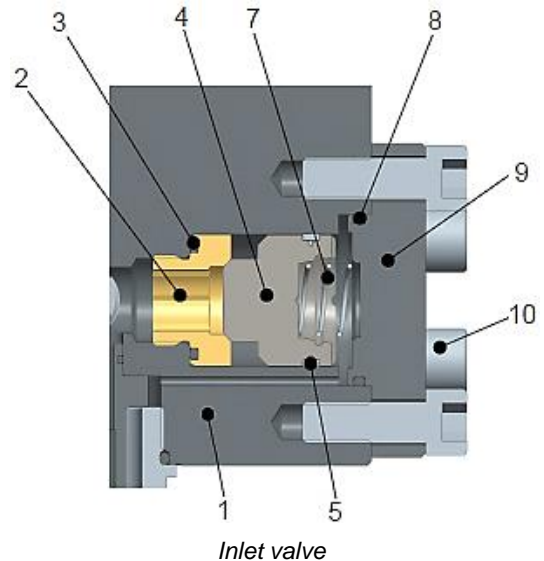

Caution - functional reliability!

Ease of movement is important for the trouble-free function.

- ▶ Fit new compression spring (7) in piston (4).
- ▶ Remove old O-ring from flange.
- ▶ Push the new, greased O-ring (8) onto the flange (9).
- ▶ Carefully insert the flange into the hole against the spring force.



Note:

Do not force the flange into the hole otherwise the O-ring may shear off.

- ▶ Apply lubricant to the thread of the hexagon socket head cap screw.
- ▶ Screw in the socket head cap screws and tighten crosswise in stages (tightening torque 30^{+5} Nm).
- ▶ Check that all screw connections are tight.
- ▶ If no other maintenance work is to be carried out: Restart the dryer (see page 36).

Recommended lubricant: Vaseline

Replacing expansion valves V3/V4

The O-rings must be replaced when changing the valves. All internal parts must be fitted without grease!

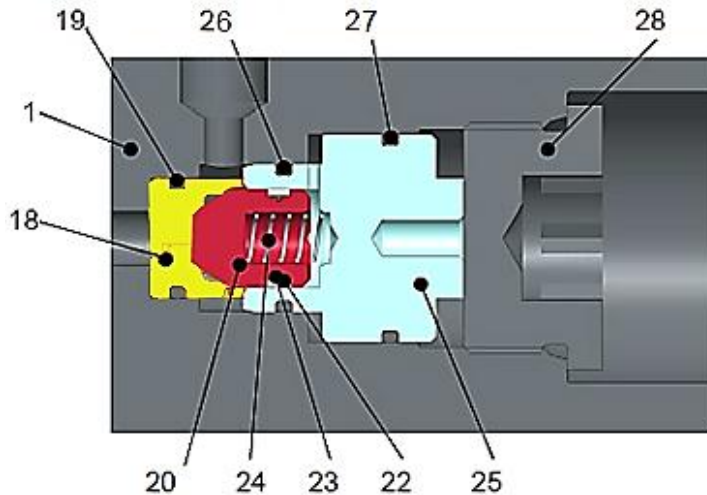

Disassembling/assembling expansion valve

- ▶ Depressurise the dryer and shut it down (see page 35).
- ▶ Undo end plug (28) (hexagon socket 22).
- ▶ Use special tool (Item 2) to remove bush (25).
- ▶ Remove the compression spring (24) and piston (20).
- ▶ Use special tool (Item 1) to carefully pull valve seat (18) out of the hole.



Caution - do not damage parts!

Do not damage valve seat. Correctly fit hook puller.

- ▶ Clean channels with compressed air.
- ▶ Fit the new, lightly greased O-rings (26, 27) on the bush.
- ▶ Fit valve seat (18) with new, lightly greased O-ring (19).
- ▶ Push the compression spring (24) and piston (20) with piston ring (22) into the sleeve (25).

Tip:

Tack the piston ring (22) with grease so that the O-ring (27) of the bush slides smoothly into the hole.

- ▶ Use special tool (Item 2) to push the bush (25) as far as it will go into the hole.

Note:

Make sure that the piston with bush is not fitted skew.

- ▶ Clean end plug and grease thread.
- ▶ Screw in end plug (28) (tightening torque 280 Nm).
- ▶ Check that all screw connections are tight.
- ▶ If no other maintenance work is to be carried out: Restart the dryer (see page 36).

Maintenance work to be completed every 24 months

In addition to the annual maintenance, the maintenance jobs described in this section must be additionally carried out every 24 months.



Danger!

There is a very considerable risk of personal injury, when carrying out work on the activated and pressurised dryer.

Maintenance tasks should only be carried out with the system switched off and depressurised.

Note:

We recommend removing the entire solenoid valve block where the dryer is difficult to access and for quicker maintenance.

In this way the maintenance work can be conveniently performed on a workbench.

Depending on the installation situation and dryer model, however, it may be necessary to remove and tilt the entire dryer for this purpose.

Replace desiccant

To replace the desiccant, it is first necessary to remove several components of the tower.

Follow the sequence described below to ensure the desiccant is changed successfully:

- ▶ Depressurise the dryer and shut it down (see page 35).

Removing check valve block



Warning - check valve block can fall off!

After releasing the screws, the check valve block is no longer fixed but rather rests loosely in position. It weighs approx. 12 kg.

Only use suitable lifting gear to lift the check valve block.

Keep valve blocks as horizontal as possible when lifting off.

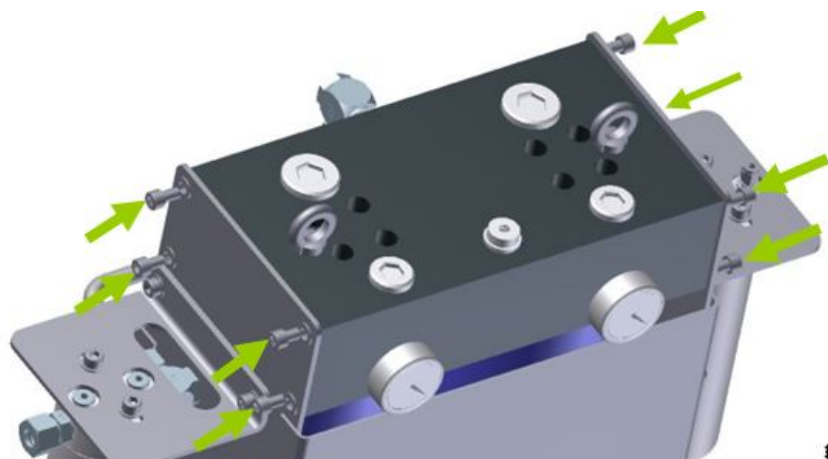

Removing check valve block

- ▶ Disconnect plug from dew point sensor.
- ▶ Remove the swivel screw connection at the dryer outlet.
- ▶ Undo piston mounting screws (8) on the check valve block.
- ▶ Undo the four frame mounting screws on either side of the block.
- ▶ Attach suitable lifting gear to the lifting eyebolts.
- ▶ Lift check valve block horizontally.

Replacing O-rings on tower connection piece

The O-rings on the tower connection pieces must be replaced as part of the 24 month maintenance routine.

- ▶ Pull out tower connection pieces
The tower connection pieces are normally pressed tightly into the block. Use Toolkit-3 to release the connection pieces simply and safely.
- ▶ Grease new O-rings and fit on the tower connection pieces.
- ▶ Reinsert tower connection pieces in the valve block.



Tower connection pieces

Replacing desiccant, seals and dust screen

The service life of the desiccant is usually approx. 2 years.

Note:

Dust sieves are installed in the vessel that retain the desiccant dust. If these dust sieves block, a dam pressure is generated that may impair the function of the dryer. When changing the purifying agent, we also recommend that you clean or renew the dust side at the same time.

Comply with the following safety notes when changing the desiccant:



Dust hazard while changing the desiccant

When emptying the desiccant, increased dust generation may occur. This desiccant dust can irritate the eyes and respiratory tract.

Wear a dust mask while changing the desiccant!

In order to avoid any eye irritations, wear protective goggles!

Risk of skidding!

If desiccant has been spilled on the floor, there is a risk of skidding caused by the desiccant beads. Therefore, spilt desiccant must always be taken up immediately.

Remove used desiccant

- ▶ The check valve block must be detached in order to remove the desiccant (see previous section).

Remove the following components from the exposed towers:



Caution - do not damage piston!

The piston is a precision component. Damage to the piston will make the dryer unusable!

- ▶ Press the piston into the tower with the special tool (Item 6) or press down using two tower mounting screws.
 - Press in the piston until the retaining segments are accessible (see arrow).
- ▶ Remove retaining segments (note order).

Tip:

Form a ring with the segments.

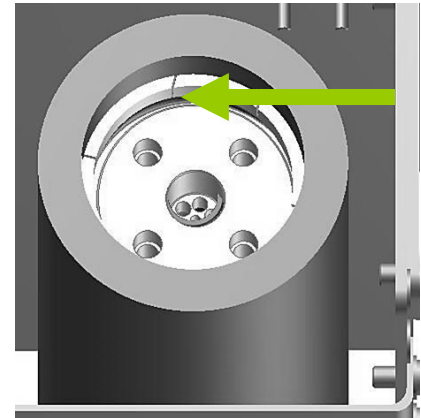

Removing piston

Note!

The piston may be firmly pressed into the tower if the dryer was pressurised beforehand. Use a suitable tool to release the piston. Make sure that you pull the piston straight upwards. **Make sure the piston is not skew!**

- ▶ Pull out the piston with the aid of the special tool (Item 6) or the tower mounting screws.
- ▶ Remove compression spring, dust sieve and perforated plate.
- ▶ Clean dust screen with compressed air.
- ▶ Extract old desiccant.

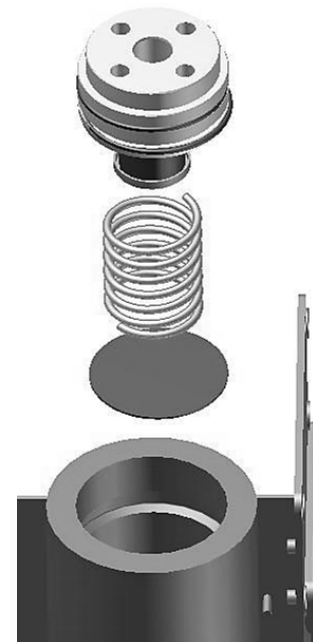

Piston, dust screen, spring and perforated plate

Desiccant layers

The tower filling consists of three different layers of desiccant.

- The bottom layer consists of ceramic beads (Duranit).
- This is followed by a protective layer of water-proof silica gel.
- The top layer of the tower is filled with a molecular sieve.

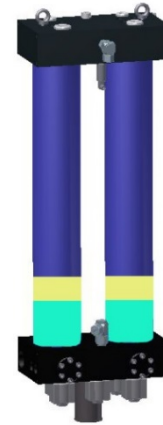

Desiccant layers

Add new desiccant

The previous sections maintenance, the maintenance jobs described in this section must be additionally carried out every 24 months. must be carried out in order to fill the dryer with fresh desiccant.

- ▶ Fill the tower with fresh preassembled desiccant packages corresponding to the layer configuration (see *above*).

Caution - do not exceed the fill level!

Do not fill up to the upper edge. Leave sufficient space for the built-in parts:

- HDK-MT 15 to 25: approx. 160 mm
- HDK-MT 30 to 70: approx. 180 mm.

- ▶ Clean dust screen with compressed air and replace on the desiccant bed.

Important!

There must be no desiccant on the dust sieve!

- ▶ Fit new dust filter with lightly greased O-ring into the piston.
- ▶ Fit compression spring.
- ▶ Replace and lightly grease O-rings on piston.
- ▶ Reinsert piston.
Pay attention to the hole pattern.
Tip: Use the frame as an alignment reference!
- ▶ Reinstall retaining segments:
 - The notch must face upwards.
 - Fit a small segment last.

Note:

The gap between the segments must not exceed max. 1 mm.

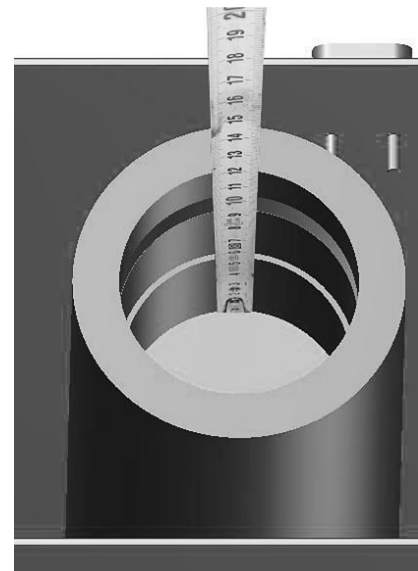

Observe fill level - clearance



Checking hole pattern

- ▶ Reinstall the check valve block with the tower connection pieces and the new O-rings (see Page 48).
- ▶ Fit all mounting screws on the check valve block and tighten (tightening torque 80 Nm).
- ▶ Secure the check valve block to the frame with the eight mounting screws.
- ▶ Reconnect the pipes to the after-filter.
- ▶ Reconnect plug of dewpoint sensor.
- ▶ Check that all screw connections are tight.
- ▶ If no other maintenance work is to be carried out: Restart the dryer (see page 36).

Replacing check valve for pressure build-up

The check valves for pressure build-up are wear parts and should be replaced every 24 months. The two valves are located on the side of the solenoid valve block.

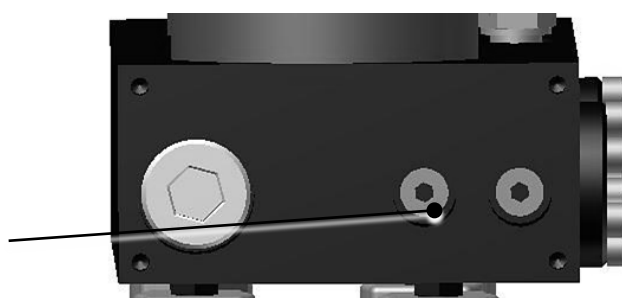

Replacing pressure build-up valve

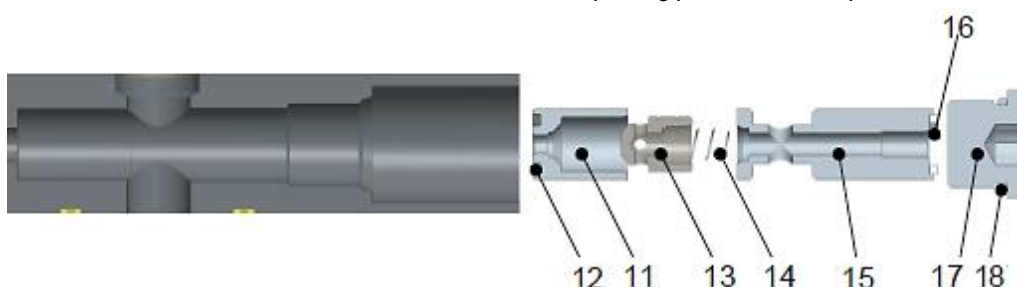

Follow the steps described in the following to change the check valves:

- ▶ Depressurise the dryer and shut it down (see page 35).
- ▶ Undo plug screw (17)
- ▶ Remove metal ring (16)

Note!

Make sure that you keep this ring (16) in a safe place and reinstall it when reassembling the check valve!

- ▶ Use special tool (Item 3) to pull out the bush (15), compression spring (14) and piston (13).
- ▶ Use special tool (Item 4) to carefully remove valve seat (11) from the hole.

The check valve has been removed.

Note on avoiding assembly errors!
Fit all internal parts without grease!
Always replace the O-rings (12, 18).

Install the new check valve as follows:

- ▶ Fit new O-ring (12) on valve seat (11).

- ▶ With the aid of special tool (Item 4), fit valve seat (11) in the hole and push in as far as it will go.
- ▶ Using special tool (Item 3), fit piston (13), compression spring (14) and bush (15) together in the hole.
- ▶ Insert the ring (16).
- ▶ Screw in screw plug (17) and tighten (tightening torque 66 Nm).
- ▶ Check that all screw connections are tight.
- ▶ If no other maintenance work is to be carried out: Restart the dryer (see page 36).

Replacing pilot control units

The pilot control units are wear parts and should be replaced every 24 months.



Take care not to damage the valve block!

- Valve seats and installation holes should be cleaned prior to assembly to ensure they are free of dust and particles.
- The valve seats of the pilot control unit are prone to misalignment.
- To ensure you do not damage the valve seat, the end sleeve must always be removed with the solenoids energised.

Note! In addition to the required safe working procedures, the following criteria must be observed when disassembling and assembling the valves and pilot control units of the dryer.

The arrangement of the pilot control units is shown in the figure opposite:

Y1, Y2

Pilot control unit of the main valves

Y3, Y4, Y5

Pilot control unit of the expansion and pressure build-up valves



Pilot control units, solenoid valve block

Replacing pilot control unit Y1/Y2 of inlet valves V1/V2

- ▶ Depressurise the dryer and shut it down (see page 35).
- ▶ Undo the nut (173) of solenoid mounting.
- ▶ Remove solenoid (170).
- ▶ Release end sleeve (116).
- ▶ Completely remove end sleeve with solenoid armature (127).
- ▶ Remove valve seat (108).

The pilot control unit Y1/Y2 has been disassembled.

Proceed as follows to install a new pilot control unit Y1/Y2:

- ▶ Replace O-ring (110) on end sleeve and install.
- ▶ Lightly grease thread of end sleeve (116).
- ▶ Fit washer (134) in end sleeve (116).
- ▶ Fit compression spring (132), pin (133), solenoid armature (127) and pin (128) on special tool (Item 5).
- ▶ Slide on end sleeve.

Important!

The pilot control unit is correctly installed when the end sleeve can be pushed down to the base of the gauge!

Tip:

Slide the end sleeve into the solenoid and energise the solenoid via rectifier connector (observe voltage supply!).

- ▶ Screw end sleeve (116) into the mounting hole.
- ▶ Remove solenoid.
- ▶ Tighten end sleeve (116) (tightening torque 100 Nm).
- ▶ Fit solenoid seal (169, 171).
- ▶ Fit solenoid onto end sleeve (116).
- ▶ Grease thread and screw on nut (173) (tightening torque 15 Nm).
- ▶ Check that all screw connections are tight.
- ▶ If no other maintenance work is to be carried out: Restart the dryer (see page 36).

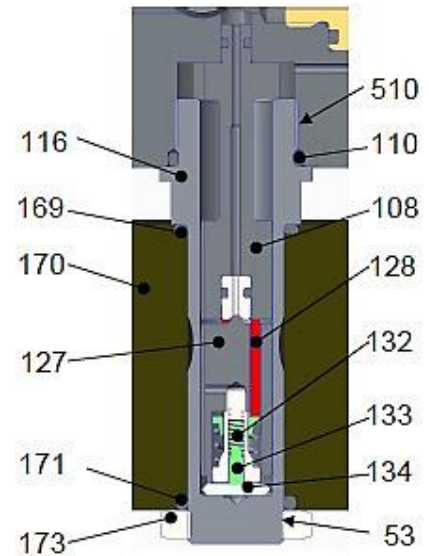

Pilot control unit Y1, Y2



Valve armature gauge



Replacing pilot control unit Y3/Y4/Y5

- ▶ Depressurise the dryer and shut it down (see page 35).
- ▶ Undo the nut (373) of solenoid mounting.
- ▶ Energise the solenoid (370).
- ▶ Remove the core tube (316). Slightly push the solenoid (370) upwards to ensure the open-ended spanner fits neatly.
- ▶ Remove the core tube with plunger (327) completely.
- ▶ De-energise the solenoid.
Caution: The solenoid armature is pressed out of the end sleeve by the spring force (332).
- ▶ Use flat-nose pliers to carefully pull valve seat (301) out of the hole.

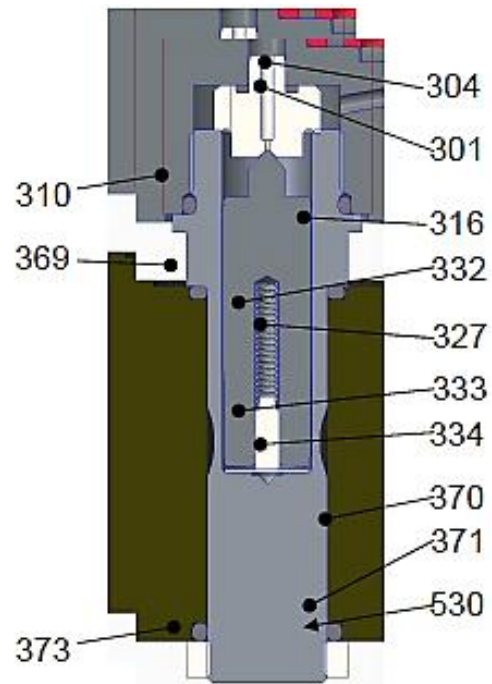

Pilot control unit Y3/Y4/Y5

The pilot control unit Y3-Y5 has been disassembled.

- ▶ Proceed as follows to install a new pilot control unit Y3/Y4/Y5:
- ▶ Fit new, lightly greased O-ring (310) onto the end sleeve (316).
- ▶ Fit valve seat (301) into the hole and push in as far as it will go.
- ▶ Fit washer (334) in end sleeve (316).
- ▶ Insert compression spring (332) and pin (333) into solenoid armature.
- ▶ Insert solenoid armature (327) into end sleeve (316).
- ▶ Fit solenoid (370) on end sleeve (316) without the seals.
- ▶ Energise the solenoid (370).
- ▶ With the solenoid armature energised, screw the end sleeve into the mounting hole and tighten (tightening torque 100^{+5} Nm).
- ▶ De-energise the solenoid.
- ▶ Fit solenoid seal (369, 371).
- ▶ Screw nut (373) onto solenoid mounting and tighten (tightening torque 15^{+3} Nm).
- ▶ Check that all screw connections are tight.
- ▶ If no other maintenance work is to be carried out: Restart the dryer (see page 36).

Other maintenance work

The maintenance tasks described in the following refer to the components with little or no wear. These components are replaced as required. You will find the necessary spare parts with the order numbers in the on Page 68.



Danger!

There is a very considerable risk of personal injury, when carrying out work on the activated and pressurised dryer.

Maintenance tasks should only be carried out with the system switched off and depressurised.

Note:

We recommend Toolkit-1 for the following tasks.

Replacing upper check valves

The check valves in the top check valve block are subject to minimal wear.

Possible signs that the valves need replacing:

- The volume of regeneration gas increases audibly.
- The dewpoint changes depending on the type of adsorbing tower.
- The pressure-built up phase is irregular.
- Unsatisfactory dewpoint values.

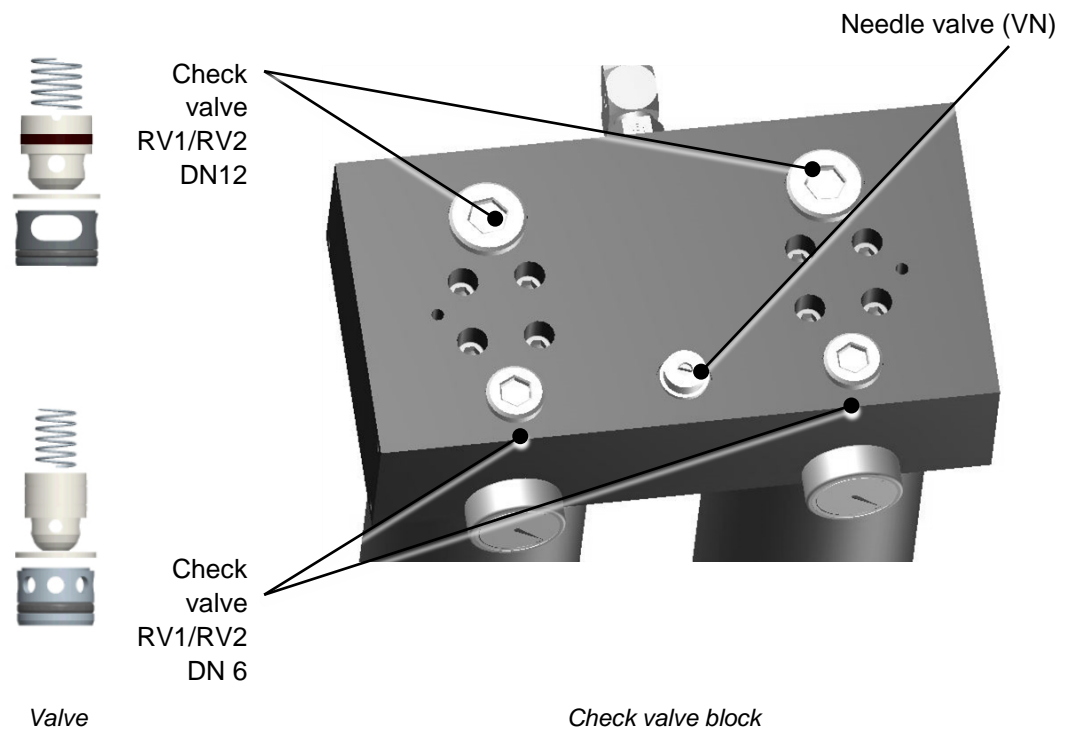

Assembling regeneration gas check valve RV3/RV4

- ▶ Depressurise the dryer and shut it down (see page 35).
- ▶ Undo end plug (18).
- ▶ Remove ring (17) from valve seat (15).
- ▶ Pull out valve seat (15) with special tool (Item 1).
- ▶ Remove piston (14) and compression spring (13) from mounting hole.

Assembling check valve

- ▶ Fit piston (14) and compression spring (13) in mounting hole.
- ▶ Fit new, greased O-ring (16) on valve seat (15).
- ▶ Insert valve seat (15) with special tool (Item 1).
- ▶ Fit ring (17) on valve seat.
- ▶ Fit new O-ring (24*) onto end plug.
- ▶ Lightly grease thread of end plug (18) and O-ring.
- ▶ Screw in end plug (tightening torque 124 Nm).
- ▶ Check that all screw connections are tight.
- ▶ If no other maintenance work is to be carried out: Restart the dryer (see page 36).

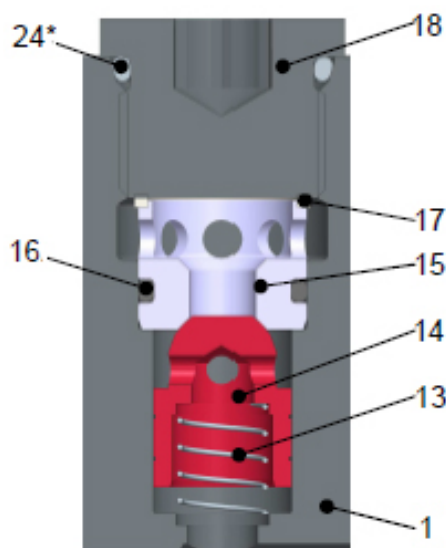

Check valve RV3/RV4

Assembling main check valve RV1/RV2

- ▶ Depressurise the dryer and shut it down (see page 35).
- ▶ Undo plug screw (11)
- ▶ Pull bush (8) out of valve plate (1) with aid of thread (M36).
- ▶ Remove piston (4) and compression spring (7) from valve plate (1).
- ▶ Remove ring (9) from valve seat (2).
- ▶ Use special tool (Item 1) to remove valve seat (2) from the mounting hole.

Assembling check valve

- ▶ Remove O-ring (3) from valve seat (2).
- ▶ Fit new O-ring (3) on valve seat (2).
- ▶ Use special tool (Item 1) to fit valve seat (2) in the mounting hole.
- ▶ Fit ring (9) on valve seat (2).
- ▶ Push the compression spring (7) and piston (4) with piston ring (5) into the sleeve (8).
- ▶ **Tip:** For easier installation lightly grease piston ring (5).
- ▶ Fit bush (8) with assembled compression spring (7) and piston (4) in the mounting hole.

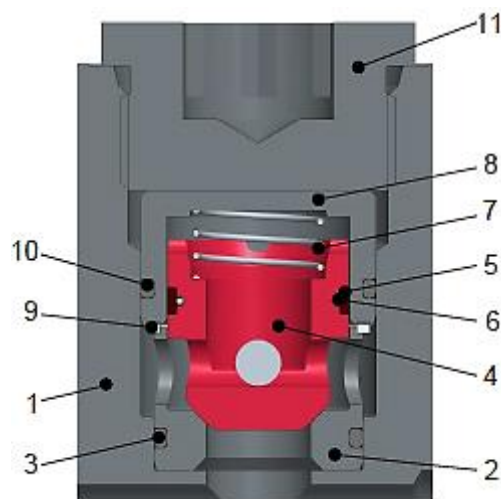

Main check valve RV1/RV2

Note!

Ensure ease of movement!

- ▶ Lightly grease thread of end plug.
- ▶ Screw in end plug and tighten (tightening torque 280 Nm).
- ▶ Check that all screw connections are tight.
- ▶ If no other maintenance work is to be carried out: Restart the dryer (see page 36).

Replacing solenoids of pilot control units Y1-Y5

The solenoids of the pilot control units are maintenance-free.

Proceed as follows to replace a defective solenoid:

- ▶ Depressurise the dryer and shut it down (see page 35).
- ▶ Disconnect plug from solenoid.
- ▶ Undo nut holding solenoid.
- ▶ Pull solenoid from end sleeve.
- ▶ Fit new solenoid on to end sleeve.

Caution:

Make sure coil voltage is correct!

- ▶ Resecure solenoid with the nut.
 - ▶ Hand-tighten nut.
-
- ▶ Check that all screw connections are tight.
 - ▶ If no other maintenance work is to be carried out: Restart the dryer (see page 36).

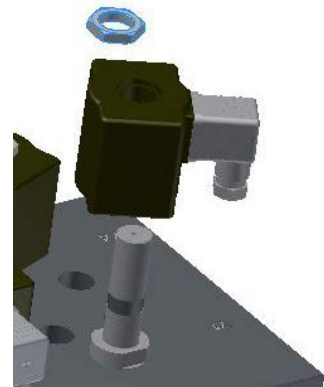

Magnet

Replacing needle valve (VN)

The regeneration gas volume indicates the amount of regeneration gas that flows through the tower to be regenerated.

The regeneration gas volume can be set with the needle valve in the check valve block. The manufacturer presets the regeneration gas volume at the factory to the specified operating data. The set value is specified on a label on the valve block.

Follow the steps described in the following to replace the needle valve:

- ▶ Depressurise the dryer and shut it down (see page 35).
- ▶ Remove the protective cap.
- ▶ Release the lock nut on the needle valve.
- ▶ Undo needle valve.
- ▶ Screw in new needle valve.
- ▶ Tighten lock nut.
- ▶ Set the regeneration gas volume as described in the next section.
- ▶ Check that all screw connections are tight.
- ▶ If no other maintenance work is to be carried out: Restart the dryer (see page 36).

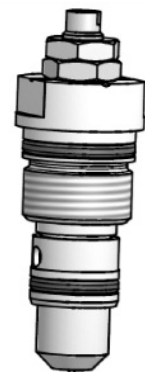

Needle valve

Setting regeneration gas volume

The manufacturer sets the regeneration gas volume at the factory with the aid of a volumetric flow measuring device.

The regeneration gas volume must be reset after replacing the needle valve or installation of a new check valve block.



Danger!

There is a very considerable risk of personal injury, when carrying out work on the activated and pressurised dryer.

The following tasks must be carried out with the system pressurised. Proceed with caution.



Warning against sudden air ejection!

During expansion the pressure is released suddenly through the muffler:

- **A loud cracking noise occurs which can injure your hearing.**
- **Particles carried in the air flow act like bullets and can injure your eyes or skin.**

Always wear eye and ear protection, therefore, when you are in the vicinity of the dryer!

- ▶ Wait until a tower has expanded and has been in the dehumidification phase for 8 minutes.

The regeneration gas volume can be set on the needle valve with a screwdriver. The number of turns to set the regeneration gas volume at the respective pressure level is specified in the following table (*table: Regeneration gas volume setting*).

Note on measuring accuracy

Setting the regeneration gas volume by the number of turns of the setting screw on the needle valve is not an exact procedure.

Therefore, after resetting the regeneration gas volume, observe for several days whether the dewpoint reading deteriorates.

If necessary, open the needle valve by a further half turn. The dewpoint should then return to the set range.

- ▶ Remove the protective cap.
- ▶ Release the lock nut on the needle valve.
- ▶ Before setting the volume, turn the screw in anticlockwise direction to the left stop to set the minimum regeneration air volume.

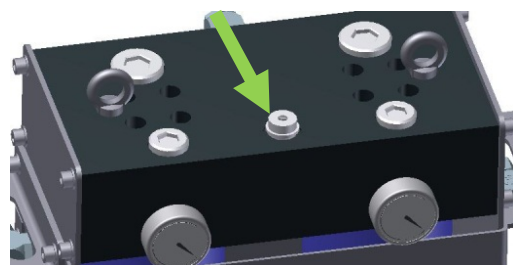

Needle valve

Note:

It is not possible to completely close the regeneration air setting valve.

- ▶ The required regeneration gas volume is set by turning the regeneration gas screw in accordance with the following table.
- ▶ Count the half and full turns of the setting screw till the required set value is reached.
- ▶ Secure the setting by tightening the lock nut.
- ▶ If no other maintenance work is to be carried out: Restart the dryer (see page 36).

Turns	Output at 100 bar	Output at 350 bar
	m ³ /h	m ³ /h
0	1.0	1.0
0.5	1.7	3.4
1	2.2	5.7
1.5	2.8	8.1
2	3.3	10.5
2.5	3.9	12.8
3	4.4	15.2
3.5	5.0	17.5
4	5.5	19.9
4.5	6.1	22.3
5	6.7	24.6
5.5	7.2	27.0
6	7.8	29.3
6.5	8.3	31.7
7	8.9	34.1
7.5	9.4	36.4
8	10.0	38.8
8.5	10.5	41.1
9	11.1	43.5
9.5	11.6	45.9
10	12.2	48.2
10.5	12.7	50.6
11	13.3	52.9
11.5	13.8	55.3
12	14.4	57.7

Table: Regeneration gas volume setting (reference values)

Identifying and eliminating faults

Overview of faults

There are different types of fault. In the case of most electrical faults (e.g. short-circuit, defective fuses, etc.) the expansion valves V3/V4 close, the inlet valves V1/V2 open and the program stops. In the case of some process faults, the dryer will continue to operate for some time. Faults on the dryer (or 'adsorber') become noticeable e.g., due to unusual noises and dam pressures.

The following table shows who is allowed to rectify a fault: the technical personnel of the operating company or trained maintenance personnel

Table of possible faults

Some faults cannot be traced back to valves not opening or closing correctly. The measures for rectifying these faults are summarised at the end of the chart.

Fault	Possible cause	Remedy	Personnel	
			Technical	Service technician
Pressure dew point is not reached	Insufficient operating pressure.	Increase operating pressure.	●	
	Differential pressure on the prefilter is too high.	Check differential pressure on the prefilter, if necessary renew filter element.		●
	Compressed air volume flow is too high.	Reduce compressed air flow rate.	●	
	Compressed air inlet temperature is too high.	Reduce compressed air inlet temperature or pre-connect a compressed air cooler.	●	●
	Condensate trap (option) on the prefilter does not work.	Check function of the condensate trap (option), if necessary clean or renew.		●
	Desiccant is contaminated or too old.	Check prefilter for contamination, if necessary renew element.		●
		Check desiccant for contamination, if necessary renew desiccant.		●
	Control board is defective.	.Check the fuses (switch cabinet, supply line) and renew the PCB if necessary		●
	Regeneration gas too low.	Check function of valve V3 / V4 and muffler, if necessary, replace muffler or filter element.		●
	RV1 – RV4 defective	Replace RV valve.		●
sensor defective	Replace sensor.		●	
Vessel pressure is too low	Differential pressure on the prefilter is too high.	Check differential pressure on the prefilter, if necessary renew filter element.		●
Excessive dam pressure during regeneration	Muffler soiled	Check mufflers for contamination, clean if necessary, and possibly renew.		●
	V3/V4 valve does not open correctly.	see *		
	Dust sieve is contaminated.	Clean or renew dust sieve.	●	●

Fault	Possible cause	Remedy	Technical personnel	Service technician
No pressure build up	The compressed air system upstream of the dryer is not pressurised.	Check whether the compressed air system upstream of the dryer is pressurised. Remove any faults.	●	
	V1/V2 or Y5 valve does not open correctly.	see *		
Excessive compressed air consumption	Condensate trap (option) on the prefilter does not work.	Check function of the condensate trap (option), if necessary clean or renew.	●	●
	Regeneration air setting too high.	Have adjusted.		●
Dryer does not switch over	Compressor might be off.	Check compressor synchronisation circuit.	●	
	Power supply interrupted, cable broken.	Reconnect the unit to the power supply.	●	
	V1/V2 valve does not open correctly.	see *		
	Error in control programme.	Restart programme.		●
	Control board is defective.	.Check the fuses (switch cabinet, supply line) and renew the PCB if necessary	●	●
No expansion	V3/V4 valve does not open correctly.	see *		
	Insufficient operating pressure.	Increase operating pressure.	●	
Dryer is continuously bled	V3/V4 valve does not close correctly.	see *		
	V1/V2 valve does not close correctly.			
* Valve does not open or close correctly.		Check supply voltage.	●	
		Check that solenoid is seated correctly.	●	
		Check valves V1-V4 for contamination; clean/replace if necessary.		●
		Check pilot control unit Y1-Y5		●
		Check cable voltage, contacts, solenoid; replace defective parts if necessary.		●

With dewpoint-sensing control

If the measured dewpoint exceeds the preset alarm limit (5 °C (41 °F) above the switchover value), the displayed dewpoint value is flashing. Error codes and their causes:

Fault code	Description	Possible cause	Remedy	Technical personnel	Service technician
+20	Upper measuring range limit exceeded	Drying capacity exceeded.	See instructions for commissioning. If the desiccant is wet, replace it.	●	
999	Dewpoint sensor defective	Sensor defective or irreversibly contaminated.	Restart programme.		●
sens or -999	Sensor not powered, or cable or sensor defective	Sensor, sensor cable or sensor adapter defective.	Visual inspection. If necessary, check 24V voltage supply at terminals 4 and 6. Replace defective component(s).		●
SEr	Display for service interval. Regular maintenance tasks must be carried out.	The display appears after every 8000 operating hours.	Inform the manufacturer's service staff and order the appropriate service kit. The package includes a dongle with which you can reset the operating hours counter after maintenance has been carried out. For instructions on how to use the dongle see the enclosed information sheet (in the service kit).	●	●

Index

A

Accident prevention regulations.....	18
Adsorption, explanation.....	15
Air ejection, hazard.....	13
Anschrift, Hersteller.....	7
Attention	
Safety instructions.....	8

B

Build no.	68
Bypass line.....	22

C

Changeover value	
For dewpoint-sensing control.....	16
Check whether only the pa.....	26
Compressed air.....	9
Compressor synchronisation.....	16, 33
Option.....	16
Connection	
Signalling, external lines.....	25
Connection lines.....	23
Connector	
electrical.....	24
Control	
dewpoint-sensing.....	16
Signalling contacts.....	16
Conversions.....	11
Cycle	
fixed.....	16
Type and duration.....	30

D

Danger	
Safety instructions.....	8
Danger warning, maintenance.....	37
Date of manufacture.....	4
Dehumidification	
Explanation.....	15
Desiccant	
Handling.....	11
Maintenance interval.....	38
Service life.....	48
Dew point	
Alarm value.....	62
Switching value.....	32, 33
Dewpoint sensor	
Maintenance interval.....	38

Dewpoint-sensing control.....	16, 33
Digital display	
Explanation.....	27
Documentation, technical.....	65
Dongle	
use.....	39
Dryer	
Maintenance interval.....	38
Drying agent	
storage.....	21
Dust generation.....	11, 48
Dust mask.....	11
Dust sieves	
Maintenance interval.....	38

E

Ear protection.....	31
Economy Cycle.....	28
Expansion, explanation.....	15

F

Fabrication no.....	4
---------------------	---

H

Hazard areas.....	13
-------------------	----

I

Installation area.....	20
Installation site, requirements.....	19

L

LEDs	
Explanation.....	26
Lifting gear.....	18
Limits, permissible.....	31

M

Machine damage, prevention.....	9
Machine passport.....	4
Mains voltage.....	66
Maintenance	
Clean muffler.....	44
Dam pressure.....	41
Desiccant.....	48
Desiccant layers.....	50
Dewpoint sensor.....	42
Renew main valves.....	44
Replace desiccant.....	47

Replace filter element.....	43
Setting regeneration gas volume.....	58
Maintenance contract.....	38
Maintenance, danger warnings	37
Misuse.....	9
Misuse, suspected	9
Modifications on the dryer.....	11
Muffler	
Maintenance interval	38

O

Operating instructions	
Safe place	8
safety notes.....	9
Target group.....	8
Operating mode	
recommended	33
Operating phases	
change	33
Operation signalling contact	
Option.....	16
Original replacement parts	38
Overpressure, hazard.....	13

P

Personnel qualification	9, 11
Phases	
Type and duration	30
Pressure build-up	
Explanation	16
sudden	31
Pressure retention valve.....	22
Programme	
sequence, steps	71
Protection class.....	66

R

Recommended installation	22
Regeneration, explanation	15
Restarting	
Pressure characteristics	36
Risk of skidding	13
Risk of slipping	
Change of desiccant.....	48

S

Safety notes	9
--------------------	---

general	10
Safety valves.....	30
Scope of delivery.....	7
Seals	
Maintenance interval	38
Service	
Details on~	4
Shutdown valves	24
Shutting down	35
Emergency	35
Sound pressure level.....	66
Spare parts.....	38
Specialist personnel	22
Standby phase	
with dew point-sensing control	16
Start-up, requirements.....	30
Storage room	
requirements	21
Supply cable, electrical.....	24
Supply line	
external	25
Supply lines.....	22
Switch box.....	14
Switchover	
Explanation	16
symbols, explanation.....	13

T

Target group.....	8
Technical personnel	8
Transport damage.....	18
Type plate	12

U

Use, proper	9
Use, safe	8

V

Vessel pressure gauge	
Maintenance interval	38
Vibration dampers	20
Visual inspection	41
Voltage	
electrical	24
Voltage, electrical.....	13

Annex with technical documentation

This annex comprises the following information and technical documentation:

- Technical data
- Replacement and wear parts list
- Logic control diagram
- Flow diagram
- Dimensional drawing

Technical data

Scope of application

Installation location	Interior installation, above freezing level, in non-aggressive atmosphere
Ambient temperature	1.5 to 50 °C
Compressed air inlet temperature	30 to 55 °C
Operating pressure, minimum/maximum — HDK-MT, pressure level 100 bar — HDK-MT, pressure level 350 bar	min. 50 bar, max. 100 bar min. 100 bar, max. 350 bar
Fluid medium	Compressed air and gaseous nitrogen
Fluid group (as per Pressure Equipment Directive)	2

Electrical connection

Mains voltage, standard	230 V, 50-60 Hz
Alternative mains voltage	115 V, 50-60 Hz
Protection class	IP65
Please note type plate and attached electrical circuit diagram!	

Noise emission

Sound level: +3 dB (A)¹	95 – 115 dB(A)
---	----------------

¹ related to free field measurement, 1 m field

Dimensions

Please observe the dimensional drawing and table with dimensions and weights on page 74.

Desiccant layers

Layer	Desiccant
Top	Molecular sieve
Middle	Silica gel (waterproof silica gel)
Bottom	Ceramic beads (Duranit)

Performance details

Type	Capacity*	Connection/ nominal width**	Tower volume	PED category	Prefilter	After-filter
	m ³ /h					
100 bar						
HDK-MT 15/100	120	½	6.0	II	GH7/100XP	GH7/100ZP/VV
HDK-MT 20/100	180	½	8.5	II	GH7/100XP	GH7/100ZP/VV
HDK-MT 25/100	240	½	10.9	III	GH7/100XP	GH7/100ZP/VV
HDK-MT 30/100	300	½	13.2	III	GH7/100XP	GH7/100ZP/VV
HDK-MT 40/100	400	¾	19.2	III	GH9/100XP	GH9/100ZP/VV
HDK-MT 50/100	520	¾	21.8	III	GH9/100XP	GH9/100ZP/VV
HDK-MT 70/100	650	¾	27.0	III	GH9/100XP	GH9/100ZP/VV
350 bar						
HDK-MT 15/350	200	½	3.7	III	GH7/350XP	GH7/350ZP/VV
HDK-MT 20/350	300	½	5.2	III	GH7/350XP	GH7/350ZP/VV
HDK-MT 25/350	400	½	6.7	III	GH7/350XP	GH7/350ZP/VV
HDK-MT 30/350	500	½	8.1	III	GH7/350XP	GH7/350ZP/VV
HDK-MT 40/350	780	¾	11.3	IV	GH9/350XP	GH9/350ZP/VV
HDK-MT 50/350	940	¾	14.2	IV	GH9/350XP	GH9/350ZP/VV
HDK-MT 70/350	1180	¾	18.0	IV	GH9/350XP	GH9/350ZP/VV

* referred to 1 bar (abs.) and 20 °C at max. operating pressure and an inlet temperature of 35 °C.

** DIN ISO 228 (BSP-P)

Replacement and wear parts list

You can order complete service kits from your distributor with the required wearing parts for the 12-month and 24-month maintenance.

Special tool kits, spare parts and accessories are additionally available.

Note:

When exchange or replacement parts are ordered, always state the dryer type and the build no. of the dryer. These data are found on the type plate.

Service kits: Preventative wearing parts kits for 100 bar and 350 bar

For model	Order No.	Maintenance	Scope of delivery
HDK-MT 15 - 30	SKH15-H30/D2/12	12 months	Reset module, prefilter/after-filter element, 4x O-ring for filter casing, 4x main valve V1-V4, 4x O-ring for tower connection piece
HDK-MT 40 - 70	SKH40-H70/D2/12		
HDK-MT 15 - 30	SKH15-H30/D2/24	24 months	Reset module, prefilter/after-filter element, 4x O-ring for filter casing, 4x main valve V1-V4 as well as 4x O-ring for tower connection piece, 4x O-ring for tower piston, 2x dust screen, 5x pilot control valve Y1-Y5, 2x check valve RV5-RV6
HDK-MT 40 - 70	SKH40-H70/D2/24		

Desmix: Preventative adsorption packs for each model

For model	Order No.	Maintenance	Scope of delivery
HDK-MT 15/100	H15/100/D2-DESMIX	24 months	The desiccant packages consist of preassembled components of the individual desiccant layers (ceramic beads, silica gel, molecular sieve).
HDK-MT 20/100	H20/100/D2-DESMIX		
HDK-MT 25/100	H25/100/D2-DESMIX		
HDK-MT 30/100	H30/100/D2-DESMIX		
HDK-MT 40/100	H40/100/D2-DESMIX		
HDK-MT 50/100	H50/100/D2-DESMIX		
HDK-MT 70/100	H70/100/D2-DESMIX		
HDK-MT 15/350	H15/350/D2-DESMIX		
HDK-MT 20/350	H20/350/D2-DESMIX		
HDK-MT 25/350	H25/350/D2-DESMIX		
HDK-MT 30/350	H30/350/D2-DESMIX		
HDK-MT 40/350	H40/350/D2-DESMIX		
HDK-MT 50/350	H50/350/D2-DESMIX		
HDK-MT 70/350	H70/350/D2-DESMIX		

Other spare parts as required

For model	Order No.	Maintenance interval	Scope of delivery
All	SDD-15/600/AL	As required	Muffler
	ZHM100/450		Dewpoint sensor
	ET-HDK-MT/2/VN		Needle valve VN (for regeneration gas)
	ET-HDK-MT/2/MV-BLOCK		Solenoid valve block without solenoid valve coils
	ET-HDK-MT/2/RV-BLOCK		Check valve block without needle valve VN, without pressure gauge
	ET-MANO.063MR0813		Pressure gauge, including seal for 100 bar
	ET-MANO.063MR0816		Pressure gauge, including seal for 350 bar
	HDK-TOOL1		Special tool kit
	HDK-TOOL2		Special tool kit
	HDK-TOOL3		Special tool kit

Repair kits: Other wearing parts kits as required

For model	Order No.	Maintenance interval	Scope of delivery
All	RKH15-H70/RV1-RV4	As required	Four RV1-RV4 check valves
	RKESC-HDK-230-NH		5 solenoid valve coils 230 V/50-60 Hz
	RKESC-HDK-115-NH		5 solenoid valve coils 115 V/50-60 Hz
	RKH15-H70/PWS		2 tower connection pieces with O-rings

Accessories, separate or installed at factory

Order No.	Description	Suitable for model
Time-controlled drain for prefilter, various mains voltages		
TRAP2/100-G230/P	Time controlled solenoid valve G1/4i, PN100, 2-55 °C, 230 VAC, IP65	All
TRAP2/100-G115/P	Time controlled solenoid valve G1/4i, PN100, 2-55 °C, 115 VAC, IP65	All
TRAP2/100-G24D/P	Time controlled solenoid valve G1/4i, PN100, 2-55 °C, 24 VDC, IP65	All
Differential pressure gauge for up- and downstream filters		
HZD80/420RG	calibrated analogue differential pressure gauge PN420	All
HZDE80/420RG	calibrated analogue differential pressure gauge PN420 with Reed contact (IP54)	All
Signal splitter		
VASMBS420	Contact 4-20 mA for analogue output of dewpoint signal	All

Start-up device		
VASVPB/450/15	Pressure retention valve G1/2 PN450 with adjustable opening pressure, including screw connection and T-piece for connection of a regeneration gas return facility	HDK-MT 15/350 to HDK-MT 30/350
VASVPB/415/20	Pressure retention valve G3/4 PN415 with adjustable opening pressure, including screw connection and T-piece for connection of a regeneration gas return facility	HDK-MT 40/100 to HDK-MT 70/100 HDK-MT 40/350 to HDK-MT 70/350
VASVPB/100/15	Pressure retention valve G1/2 PN100 with adjustable opening pressure, including screw connection and T-piece for connection of a regeneration gas return facility	HDK-MT 15/100 to HDK-MT 30/100

Logic control diagram

Adsorption in B1 and regeneration in B2

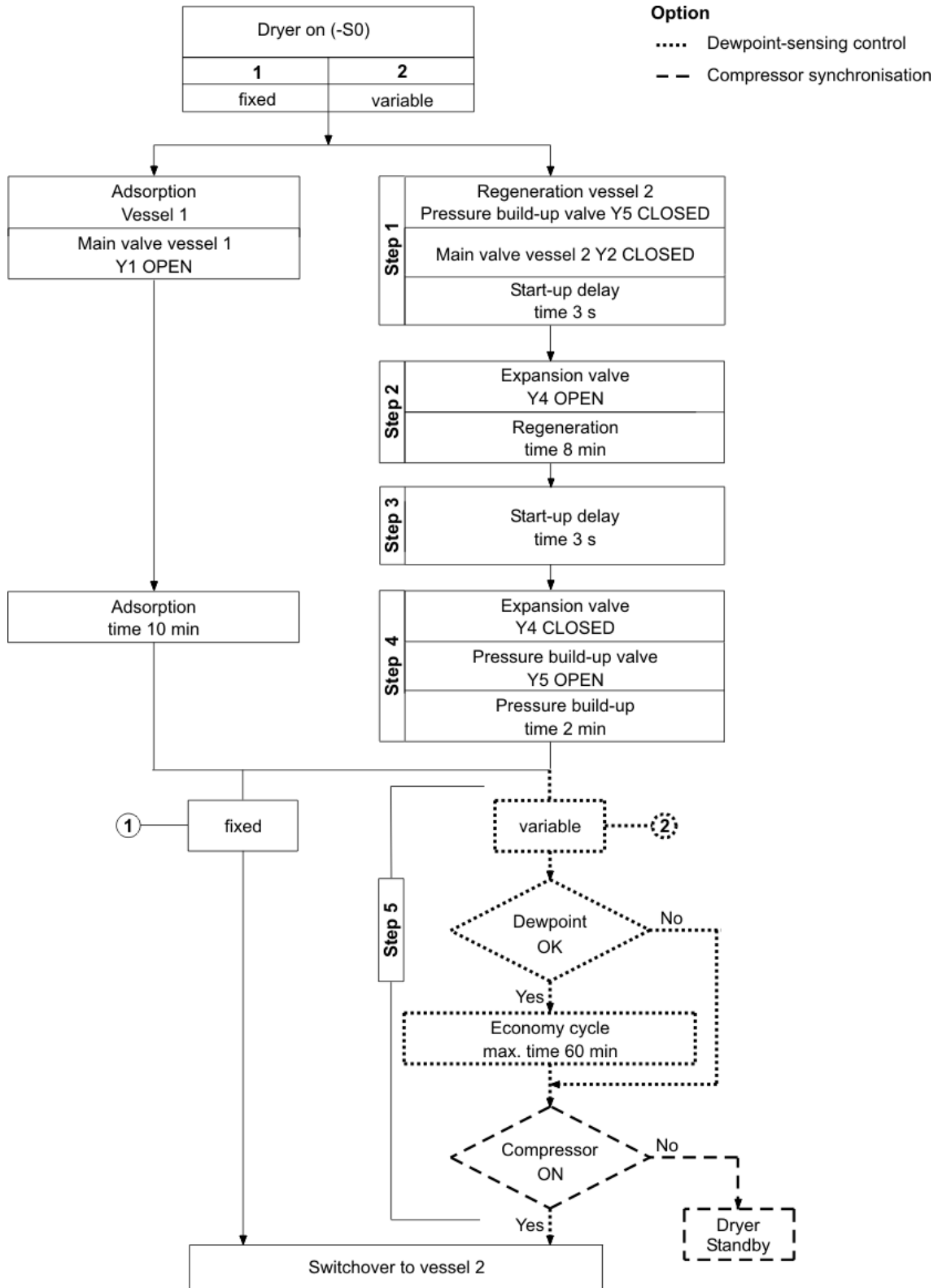

Regeneration in B1 and adsorption in B2

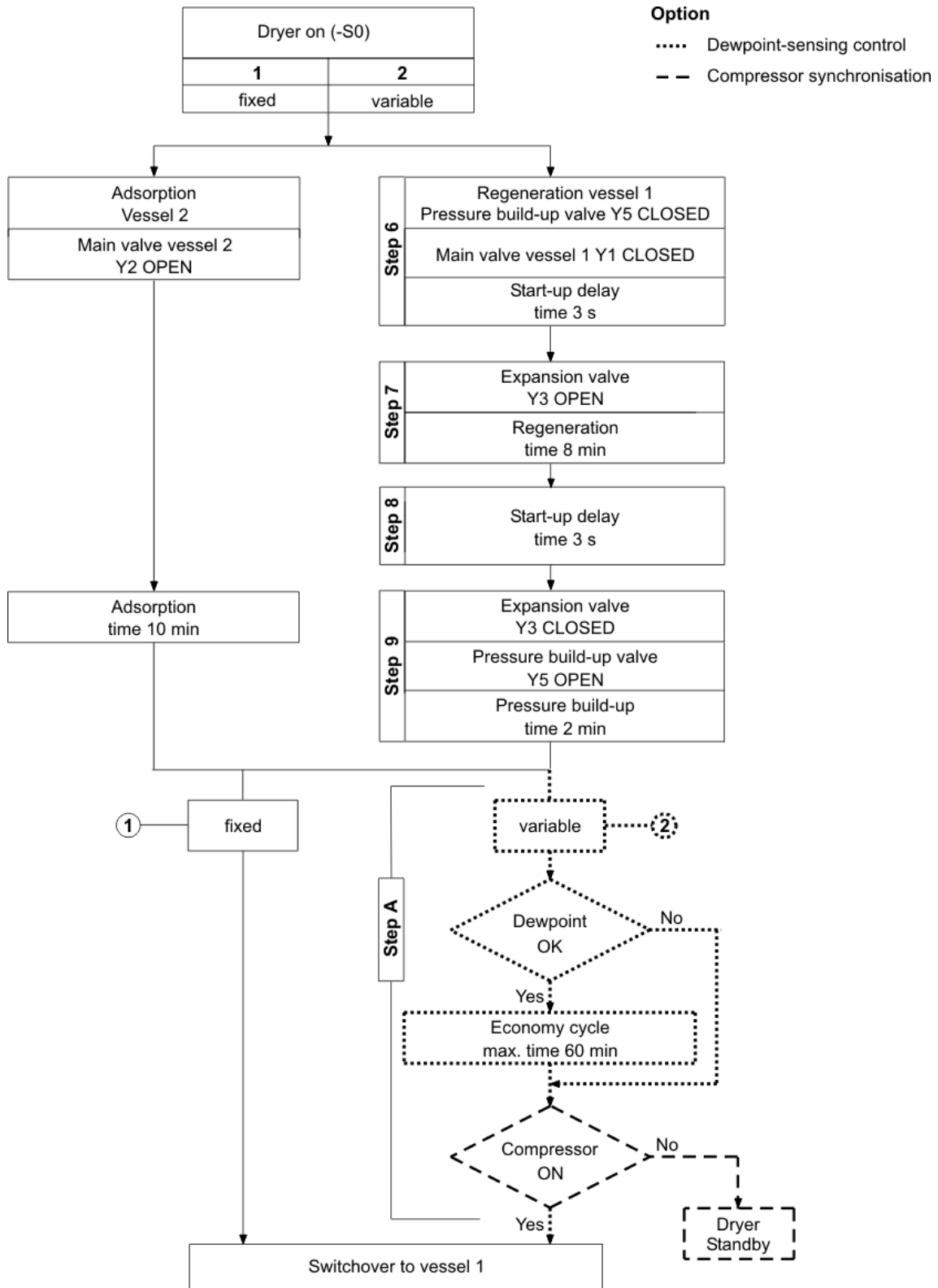

Flow diagram

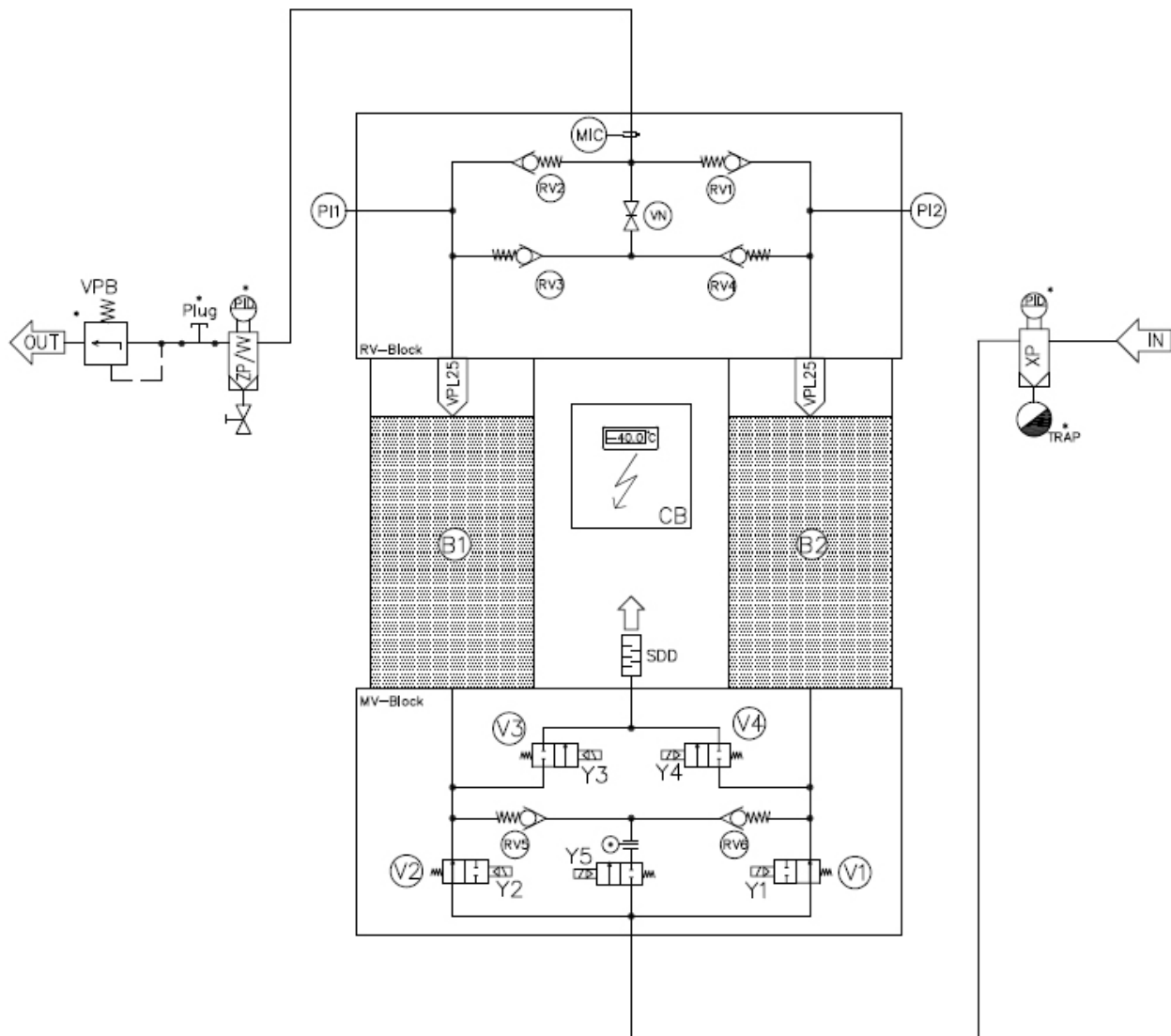

Item	Description
B1, B2	Hopper
V1-V4	Main valve
Y1-Y5	Pilot valves
SDD	Muffler
CB	Control system
XP	Prefilter
ZP/VV	After-filter
VN	Needle valve
MIC	Dewpoint sensor

Item	Description
PI1, PI2	Pressure gauge
RV1- RV6	Check valves
VPL25	Dust sieve
Optional*:	
VPB	Start-up device
PID	Differential pressure gauge
TRAP	Time-controlled drain
Plug	T-piece

Dimensional drawing

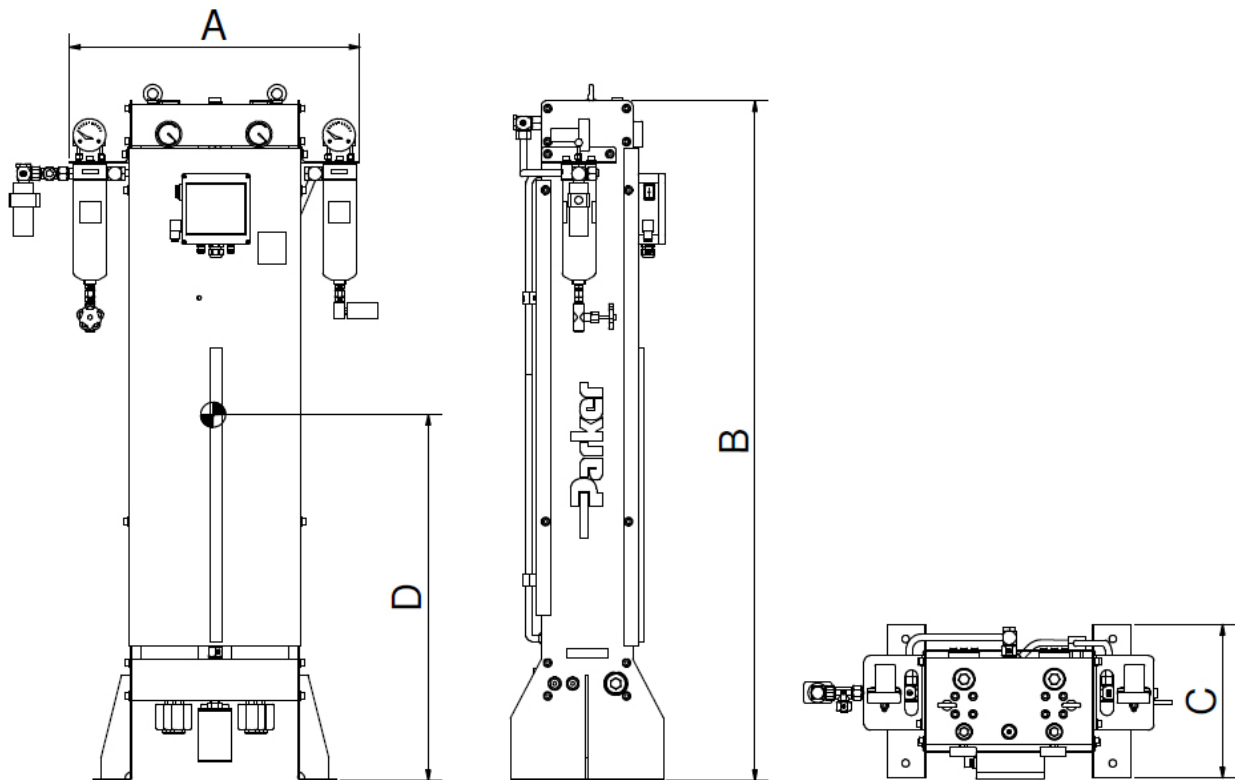

Type	Connection	Dimensions [mm]				Weight [kg]	
		A	B	C	D	100bar	350bar
HDK-MT 15/...	½	700	1050	370	300	160	190
HDK-MT 20/...	½	700	1250	370	480	180	220
HDK-MT 25/...	½	700	1450	370	680	200	250
HDK-MT 30/...	½	700	1650	370	880	220	280
HDK-MT 40/...	¾	770	1650	370	1100	240	310
HDK-MT 50/...	¾	770	1850	450	1300	260	340
HDK-MT 70/...	¾	770	2075	450	1500	280	380